



Fire Alarm Control Panel
NFS2-3030/E
Installation Manual

Document 52544	K1
02/14/2012	
P/N 52544:K1	ECN 12-0150

Fire Alarm System Limitations

While a fire alarm system may lower insurance rates, it is not a substitute for fire insurance!

An automatic fire alarm system—typically made up of smoke detectors, heat detectors, manual pull stations, audible warning devices, and a fire alarm control panel with remote notification capability—can provide early warning of a developing fire. Such a system, however, does not assure protection against property damage or loss of life resulting from a fire.

The Manufacturer recommends that smoke and/or heat detectors be located throughout a protected premise following the recommendations of the current edition of the National Fire Protection Association Standard 72 (NFPA 72), manufacturer's recommendations, State and local codes, and the recommendations contained in the Guides for Proper Use of System Smoke Detectors, which are made available at no charge to all installing dealers. These documents can be found at <http://www.systemsensor.com/html/applicat.html>. A study by the Federal Emergency Management Agency (an agency of the United States government) indicated that smoke detectors may not go off in as many as 35% of all fires. While fire alarm systems are designed to provide early warning against fire, they do not guarantee warning or protection against fire. A fire alarm system may not provide timely or adequate warning, or simply may not function, for a variety of reasons:

Smoke detectors may not sense fire where smoke cannot reach the detectors such as in chimneys, in or behind walls, on roofs, or on the other side of closed doors. Smoke detectors also may not sense a fire on another level or floor of a building. A second-floor detector, for example, may not sense a first-floor or basement fire.

Particles of combustion or "smoke" from a developing fire may not reach the sensing chambers of smoke detectors because:

- Barriers such as closed or partially closed doors, walls, or chimneys may inhibit particle or smoke flow.
- Smoke particles may become "cold," stratify, and not reach the ceiling or upper walls where detectors are located.
- Smoke particles may be blown away from detectors by air outlets.
- Smoke particles may be drawn into air returns before reaching the detector.

The amount of "smoke" present may be insufficient to alarm smoke detectors. Smoke detectors are designed to alarm at various levels of smoke density. If such density levels are not created by a developing fire at the location of detectors, the detectors will not go into alarm.

Smoke detectors, even when working properly, have sensing limitations. Detectors that have photoelectronic sensing chambers tend to detect smoldering fires better than flaming fires, which have little visible smoke. Detectors that have ionizing-type sensing chambers tend to detect fast-flaming fires better than smoldering fires. Because fires develop in different ways and are often unpredictable in their growth, neither type of detector is necessarily best and a given type of detector may not provide adequate warning of a fire.

Smoke detectors cannot be expected to provide adequate warning of fires caused by arson, children playing with matches (especially in bedrooms), smoking in bed, and violent explosions (caused by escaping gas, improper storage of flammable materials, etc.).

Heat detectors do not sense particles of combustion and alarm only when heat on their sensors increases at a predetermined rate or reaches a predetermined level. Rate-of-rise heat detectors may be subject to reduced sensitivity over time. For this reason, the rate-of-rise feature of each detector should be tested at least once per year by a qualified fire protection specialist. Heat detectors are designed to protect property, not life.

IMPORTANT! Smoke detectors must be installed in the same room as the control panel and in rooms used by the system for the connection of alarm transmission wiring, communications, signaling, and/or power. If detectors are not so located, a developing fire may damage the alarm system, crippling its ability to report a fire.

Audible warning devices such as bells may not alert people if these devices are located on the other side of closed or partly open doors or are located on another floor of a building. Any warning device may fail to alert people with a disability or those who have recently consumed drugs, alcohol or medication. Please note that:

- Strobes can, under certain circumstances, cause seizures in people with conditions such as epilepsy.
- Studies have shown that certain people, even when they hear a fire alarm signal, do not respond or comprehend the meaning of the signal. It is the property owner's responsibility to conduct fire drills and other training exercise to make people aware of fire alarm signals and instruct them on the proper reaction to alarm signals.
- In rare instances, the sounding of a warning device can cause temporary or permanent hearing loss.

A fire alarm system will not operate without any electrical power. If AC power fails, the system will operate from standby batteries only for a specified time and only if the batteries have been properly maintained and replaced regularly.

Equipment used in the system may not be technically compatible with the control panel. It is essential to use only equipment listed for service with your control panel.

Telephone lines needed to transmit alarm signals from a premise to a central monitoring station may be out of service or temporarily disabled. For added protection against telephone line failure, backup radio transmission systems are recommended.

The most common cause of fire alarm malfunction is inadequate maintenance. To keep the entire fire alarm system in excellent working order, ongoing maintenance is required per the manufacturer's recommendations, and UL and NFPA standards. At a minimum, the requirements of NFPA 72 shall be followed. Environments with large amounts of dust, dirt or high air velocity require more frequent maintenance. A maintenance agreement should be arranged through the local manufacturer's representative. Maintenance should be scheduled monthly or as required by National and/or local fire codes and should be performed by authorized professional fire alarm installers only. Adequate written records of all inspections should be kept.

Limit-C1-2-2007

Installation Precautions

Adherence to the following will aid in problem-free installation with long-term reliability:

WARNING - Several different sources of power can be connected to the fire alarm control panel. Disconnect all sources of power before servicing. Control unit and associated equipment may be damaged by removing and/or inserting cards, modules, or interconnecting cables while the unit is energized. Do not attempt to install, service, or operate this unit until manuals are read and understood.

CAUTION - System Re-acceptance Test after Software Changes: To ensure proper system operation, this product must be tested in accordance with NFPA 72 after any programming operation or change in site-specific software. Re-acceptance testing is required after any change, addition or deletion of system components, or after any modification, repair or adjustment to system hardware or wiring. All components, circuits, system operations, or software functions known to be affected by a change must be 100% tested. In addition, to ensure that other operations are not inadvertently affected, at least 10% of initiating devices that are not directly affected by the change, up to a maximum of 50 devices, must also be tested and proper system operation verified.

This system meets NFPA requirements for operation at 0-49° C/32-120° F and at a relative humidity 93% ± 2% RH (non-condensing) at 32°C ± 2°C (90°F ± 3°F). However, the useful life of the system's standby batteries and the electronic components may be adversely affected by extreme temperature ranges and humidity. Therefore, it is recommended that this system and its peripherals be installed in an environment with a normal room temperature of 15-27° C/60-80° F.

Verify that wire sizes are adequate for all initiating and indicating device loops. Most devices cannot tolerate more than a 10% I.R. drop from the specified device voltage.

Like all solid state electronic devices, this system may operate erratically or can be damaged when subjected to lightning induced transients. Although no system is completely immune from lightning transients and interference, proper grounding will reduce susceptibility. Overhead or outside aerial wiring is not recommended, due to an increased susceptibility to nearby lightning strikes. Consult with the Technical Services Department if any problems are anticipated or encountered.

Disconnect AC power and batteries prior to removing or inserting circuit boards. Failure to do so can damage circuits.

Remove all electronic assemblies prior to any drilling, filing, reaming, or punching of the enclosure. When possible, make all cable entries from the sides or rear. Before making modifications, verify that they will not interfere with battery, transformer, or printed circuit board location.

Do not tighten screw terminals more than 9 in-lbs. Overtightening may damage threads, resulting in reduced terminal contact pressure and difficulty with screw terminal removal.

This system contains static-sensitive components. Always ground yourself with a proper wrist strap before handling any circuits so that static charges are removed from the body. Use static suppressive packaging to protect electronic assemblies removed from the unit.

Follow the instructions in the installation, operating, and programming manuals. These instructions must be followed to avoid damage to the control panel and associated equipment. FACP operation and reliability depend upon proper installation.

Precau-D1-9-2005

FCC Warning

WARNING: This equipment generates, uses, and can radiate radio frequency energy and if not installed and used in accordance with the instruction manual may cause interference to radio communications. It has been tested and found to comply with the limits for class A computing devices pursuant to Subpart B of Part 15 of FCC Rules, which is designed to provide reasonable protection against such interference when devices are operated in a commercial environment. Operation of this equipment in a residential area is likely to cause interference, in which case the user will be required to correct the interference at his or her own expense.

Canadian Requirements

This digital apparatus does not exceed the Class A limits for radiation noise emissions from digital apparatus set out in the Radio Interference Regulations of the Canadian Department of Communications.

Le present appareil numerique n'emet pas de bruits radioelectriques depassant les limites applicables aux appareils numeriques de la classe A prescrites dans le Reglement sur le brouillage radioelectrique edicte par le ministere des Communications du Canada.

HARSH™, NIS™, Notifier Integrated Systems™, and NOTI-FIRE-NET™ are all trademarks; and **Acclimate® Plus, FlashScan®, NION®, NOTIFIER®, ONYX®, ONYXWorks®, UniNet®, VeriFire®, and VIEW®** are all registered trademarks of Honeywell International Inc. **Echelon®** is a registered trademark and **LonWorks™** is a trademark of Echelon Corporation. **ARCNET®** is a registered trademark of Datapoint Corporation. **Microsoft®** and **Windows®** are registered trademarks of the Microsoft Corporation.

©Thursday, March 22, 2012 by Honeywell International Inc. All rights reserved. Unauthorized use of this document is strictly prohibited.

Software Downloads

In order to supply the latest features and functionality in fire alarm and life safety technology to our customers, we make frequent upgrades to the embedded software in our products. To ensure that you are installing and programming the latest features, we strongly recommend that you download the most current version of software for each product prior to commissioning any system. Contact Technical Support with any questions about software and the appropriate version for a specific application.

Documentation Feedback

Your feedback helps us keep our documentation up-to-date and accurate. If you have any comments or suggestions about our online Help or printed manuals, you can email us.

Please include the following information:

- Product name and version number (if applicable)
- Printed manual or online Help
- Topic Title (for online Help)
- Page number (for printed manual)
- Brief description of content you think should be improved or corrected
- Your suggestion for how to correct/improve documentation

Send email messages to:

FireSystems.TechPubs@honeywell.com

Please note this email address is for documentation feedback only. If you have any technical issues, please contact Technical Services.

Table of Contents

Section 1: About This Manual	7
1.1: Standards and Other Documents	7
1.2: UL 864 Compliance	8
1.2.1: Products Subject to AHJ Approval	8
1.3: Related Documents	8
1.4: Cautions and Warnings	10
Section 2: System Overview	12
2.1: System Description	12
2.1.1: Standard Features	12
2.1.2: Options	12
2.1.3: System Limitations	14
2.2: System Components	14
2.3: Product Diagram	15
2.3.1: Main Power Supply	16
2.4: System Cabinets	17
2.5: Compatible Equipment	18
Section 3: Installation	20
3.1: Preparing for Installation	20
3.2: Installation Checklist	20
3.3: Mounting a Cabinet	21
3.4: Laying Out Equipment in Cabinet and Chassis	23
3.5: Attaching the CPU & Chassis	24
3.5.1: Mounting in CHS-M3	24
3.5.2: Mounting in the CA-2 Audio System Chassis	25
3.5.3: Mounting Chassis in Backbox	26
3.5.4: Memory-Backup Battery	26
3.6: Attaching Option Boards	27
3.7: Connecting the Network Communications Module	29
3.8: Connecting the Loop Control and Expander Modules	29
3.8.1: Mounting Instructions	29
3.8.2: Audio Applications with Chassis CA-2	30
3.8.3: Setting SLC Loop Number	30
3.8.4: Enabling External Power Supervision	30
3.8.5: Installing a Multi-layer Module into the Chassis	31
3.9: Form-C Relays on the CPU	34
3.10: Connecting Power Sources and Outputs	34
3.10.1: Overview	34
3.10.2: Connecting the Power Supply	35
3.10.3: Checking AC Power	35
3.10.4: Auxiliary Power Supply Connections	36
3.11: UL Power-limited Wiring Requirements	36
3.12: Central Station Fire Alarm System Canadian Requirements	38
3.13: ULC Remote Connection Feature	39
3.14: Installing Printers	39
3.14.1: Printer Installation Sequence	40
3.14.2: Configuring the Printer	41
3.15: Wiring a Signaling Line Circuit (SLC)	42
3.15.1: SLC Overview	42
3.15.2: SLC Capacity	42
3.15.3: SLC Installation	43
3.16: Connecting a PC for Programming	43

Section 4: Applications	44
4.1: Overview	44
4.2: Devices Requiring External Power Supervision	44
4.3: NFPA 72 Central or Remote Station Fire Alarm System (Protected Premises Unit)	45
4.4: NFPA 72 Proprietary Fire Alarm Systems	46
4.5: Fire/Security Applications	47
4.5.1: General Operation	47
4.5.2: General Security Requirements	47
4.5.3: Installing a Security Tamper Switch	48
4.5.4: Receiving Unit	49
4.5.5: Programming	49
4.5.6: Wiring for Proprietary Security Alarm Applications	49
4.5.7: Connecting an RKS-S Remote Key Switch	50
4.5.8: Single Tenant Security System with Entry/Exit Delay	51
4.5.9: Security Annunciation	53
4.6: Releasing Applications	53
4.6.1: Overview	53
4.6.2: Programming	53
4.6.3: Wiring	54
4.7: Connecting a Releasing Device to FCM-1 Control Modules (Retrofit applications only)	54
4.8: Connecting Releasing Devices to FCM-1-REL Control Modules	55
4.9: Connecting an NBG-12LRA Agent Release-Abort Station	56
Section 5: Testing the System	58
5.1: Acceptance Test	58
5.2: Periodic Testing and Service	58
5.3: Operational Checks	58
5.4: Battery Checks and Maintenance	59
Appendix A: Electrical Specifications	62
A.1: Operating Power	62
A.2: SLC Loops	62
A.3: Notification Appliance Circuits	62
A.4: Wire Requirements	62
Appendix B: Canadian Applications	64
B.1: Standalone Application	64
B.2: Local Network Application	64
B.3: Automatic Alarm Signal Silence	64
B.4: Annunciator Applications	64
B.5: Releasing Devices	64
B.6: Canadian SLC Devices	64
Index	65

Section 1: About This Manual

1.1 Standards and Other Documents



■ **This Fire Alarm Control Panel complies with the following NFPA standards:**

- NFPA 12A Halon 1301 Extinguishing Systems
- NFPA 13 Sprinkler Systems
- NFPA 15 Water Spray Systems
- NFPA 16 Foam/Water Deluge and Foam/Water Spray Systems
- NFPA 17 Dry Chemical Extinguishing Systems
- NFPA 17A Wet Chemical Extinguishing Systems
- NFPA 72 Central Station Fire Alarm Systems (Automatic, Manual and Waterflow) Protected Premises Unit (requires Notifier UDACT/UDACT-2).
- NFPA 72 Local (Automatic, Manual, Waterflow and Sprinkler Supervisory) Fire Alarm Systems.
- NFPA 72 Auxiliary (Automatic, Manual and Waterflow) Fire Alarm Systems (requires TM-4).
- NFPA 72 Remote Station (Automatic, Manual and Waterflow) Fire Alarm Systems
- NFPA 72 Proprietary (Automatic, Manual and Waterflow) Fire Alarm Systems (Protected Premises Unit).
- NFPA 2001 Clean Agent Fire Extinguishing Systems

■ **The installer should be familiar with the following documents and standards:**

- NFPA 72 Initiating Devices for Fire Alarm Systems
- NFPA 72 Inspection, Testing and Maintenance for Fire Alarm Systems
- NFPA 72 Notification Appliances for Fire Alarm Systems



Underwriters Laboratories (UL)

- UL 38 Manually Actuated Signaling Boxes
- UL 217 Smoke Detectors, Single and Multiple Station
- UL 228 Door Closers - Holders for Fire Protective Signaling Systems
- UL 268 Smoke Detectors for Fire Protective Signaling Systems
- UL 268A Smoke Detectors for Duct Applications
- UL 346 Waterflow Indicators for Fire Protective Signaling Systems
- UL 464 Audible Signaling Appliances
- UL 521 Heat Detectors for Fire Protective Signaling Systems
- UL 864 Standard for Control Units for Fire Protective Signaling Systems
- UL 1481 Power Supplies for Fire Protective Signaling Systems
- UL 1971 Visual Signaling Appliances
- UL 1076 Proprietary Burglar Alarm Systems
- UL 2017 Standard for General-Purpose Signaling Devices and Systems



Underwriters Laboratories of Canada (ULC)

- ULC-S527-99 Standard for Control Units for Fire Alarm Systems
- ULC S524 Standard for the Installation of Fire Alarm Systems

Other

- EIA-485 and EIA-232 Serial Interface Standards
- NEC Article 300 Wiring Methods

- NEC Article 760 Fire Protective Signaling Systems
- Applicable Local and State Building Codes
- Requirements of the Local Authority Having Jurisdiction
- Canadian Electrical Code, Part 1

1.2 UL 864 Compliance

1.2.1 Products Subject to AHJ Approval

This product has been certified to comply with the requirements in the Standard for Control Units and Accessories for Fire Alarm Systems, UL 864 9th Edition.

The following products have not received UL 864 9th Edition certification and may only be used in retrofit applications. Operation of the NFS2-3030/E with products not tested for UL 864 9th Edition has not been evaluated and may not comply with NFPA 72 and/or the latest edition of UL 864. These applications will require the approval of the local Authority Having Jurisdiction (AHJ).

- For a complete list of all peripherals that can be used with this fire alarm control panel (FACP), and which of those peripherals have not received UL 864, 9th Edition certification and may only be used in retrofit applications, see Section 2.5, “Compatible Equipment”, on page 18.

1.3 Related Documents

The table below provides a list of documents referenced in this manual, as well as documents for selected other compatible devices. The document series chart (DOC-NOT) provides the current document revision. A copy of this document is included in every shipment.

Compatible Conventional Devices (Non-addressable)	Document Number
Device Compatibility Document	15378
Fire Alarm Control Panel (FACP) and Main Power Supply Installation	Document Number
NFS2-3030 Installation, Programming and Operations Manuals	52544, 52545, 52546
AMPS-24/E Addressable Power Supply Manual	51907
DVC Digital Voice Command Manual	52411
DVC-RPU Manual	50107425-001
DVC-RPU UL Listing Document	50107424-001
DAA2 and DAX Amplifiers Manual	53265
DS-DB Digital Series Distribution Board and Amplifier	53622
DAL Devices Reference Document	52410
AA-Series Audio Amplifier Manual	52526
SLC Wiring Manual	51253
Note: For individual SLC Devices, refer to the <i>SLC Wiring Manual</i>	
*Note: Also documents some retrofit equipment manufactured under UL 8th edition	
Off-line Programming Utility	Document Number
VeriFire® Tools CD help file	VERIFIRE-TCD
Power Supply Programming Utility	PK-PPS
Cabinets & Chassis	Document Number
CAB-3/CAB-4 Series Cabinet Installation Document	15330
Battery/Peripherals Enclosure Installation Document	50295
Heat Dissipation for Cabinets with Digital Audio Products	53645

Table 1.1 Related Documents (1 of 2)

Power Supplies, Auxiliary Power Supplies & Battery Chargers	Document Number
ACPS-2406 Installation Manual	51304
ACPS-610 Installation Manual	53018
APS2-6R Instruction Manual	53232
CHG-120 Battery Charger Manual	50641
FCPS-24 Field Charger/Power Supply Manual	50059
FCPS-24S6/FCPS-24S8 Field Charger/Power Supply	51977
Networking	Document Number
High-Speed Network Communications Module	54014
High-Speed Noti•Fire•Net Instruction Manual	54013
Noti•Fire•Net Manual, Network Version 5.0	51584
NCM-W/F Installation Document	51533
NCS Network Control Station, Network Version 5.0 & Higher Manual	51658
NCA-2 Network Control Annunciator Manual	52482
NCA Network Control Annunciator Manual	51482
ONYXWorks® Workstation	52342
System Components	Document Number
Annunciator Control System Manual	15842
ACM-8R Annunciator Control Module Manual	15342
ACT-1 Installation Document	52527
LCD-80 Manual	15037
LCD2-80 Manual	53242
LCD-160 Manual	51850
LDM Series Lamp Driver Annunciator Manual	15885
SCS Smoke Control Manual (Smoke and HVAC Control Station) Manual	15712
DPI-232 Manual	51499
TM-4 Installation Document (Reverse Polarity Transmitter)	51490
UDACT Manual (Universal Digital Alarm Communicator/Transmitter)	50050
UDACT-2 Manual (Universal Digital Alarm Communicator/Transmitter)	54089
ACT-2 Installation Document	51118
FireVoice 25/50 Series Manual	52290
RM-1 Series Remote Microphone Installation Document	51138
RA100Z Remote LED Annunciator Document	I56-0508
UZY-256 Universal Zone Coder Manual	15216
UZY-256 Programming Manual	15976
XP Transponder Manual	15888
XP10-M Ten Input Monitor Module Installation Document	I56-1803
XP6-C Supervised Control Module Installation Document	I56-1805
XP6-MA Six Zone Interface Module Installation Document	I56-1806
XP6-R Six Relay Control Module Installation Document	I56-1804
XPIQ Audio Transponder Manual	51013

Table 1.1 Related Documents (2 of 2)



NOTE: Where used in this manual, the term CPU refers to the main circuit board for the fire alarm control panel's central processing unit (see Section 2.2 "System Components" for a more detailed list of part numbers.)

1.4 Cautions and Warnings

This manual contains cautions and warnings to alert the reader as follows:



CAUTION: SUMMARY IN BOLD

INDICATES INFORMATION ABOUT PROCEDURES THAT COULD CAUSE PROGRAMMING ERRORS, RUNTIME ERRORS, OR EQUIPMENT DAMAGE.



WARNING: SUMMARY IN BOLD

INDICATES INFORMATION ABOUT PROCEDURES THAT COULD CAUSE IRREVERSIBLE DAMAGE TO THE CONTROL PANEL, IRREVERSIBLE LOSS OF PROGRAMMING DATA OR PERSONAL INJURY.

Notes

Section 2: System Overview

2.1 System Description

This manual describes the NFS2-3030, based on the CPU2-3030D (with display) and CPU2-3030ND (without display). It differs from the NFS-3030 as follows:

- It has been modified to include more memory.
- The display contains more information – a “Controls Active” LED and an “Acknowledge” button.
- There are no panel module circuits – panel circuit module functions are performed by Digital Voice Command equipment and SLC devices.

2.1.1 Standard Features

- Connections to easily mount from one to ten Signaling Line Circuit (SLC) loops
- Network operation
- Uses Notifier’s VIEW® early warning fire detection and the FlashScan® or CLIP families of detectors and modules
- Alarm, Trouble, Supervisory and Security relays
- Support for 32 annunciator addresses with either 64 or 96 points each (depending on the capability of the annunciator)
- Supports Style 4, Style 6, Style 7 SLC loops
- Logic Equations
- Multi-line display
- Ability to activate local sounder or relay bases in alarm or pre-alarm
- Alarm verification pre-alarm indication (NYC)
- Supervisory duct and smoke detectors
- Supports Intelligent Sensing algorithms
- EIA-485 connections for wiring ACS annunciators (including LDM custom graphic annunciators), TM-4 transmitter
- EIA-232 connection for printer
- Autoprogram feature for faster programming of new devices
- Easy connection to VeriFire® Tools programming utility
- The basic system power supply is addressable, charges sealed lead-acid batteries ranging in capacity from 7 to 200 amp hours, and provides up to 5 amps of power for use by the CPU.
- Easy connection to auxiliary power supplies and battery chargers for custom design of very large systems.
- Diagnostic LEDs and switches
- Ground fault detection
- Support for Remote Text Display (LCD-160)
- Support for Display and Control Center (DCC) functionality

2.1.2 Options

Refer to Section 2.2 “System Components” for descriptions of the various optional modules.

- Rubberized keypad with a standard “QWERTY” keyboard layout, a 640-character LCD display, indicator LEDs, and switches.

- Separately ordered Loop Control Modules and Loop Expander Modules provide up to ten SLC loops.
- Optional equipment includes: ACS devices, UDACT/UDACT-2 Universal Digital Alarm Communicator/Transmitter, ACM-8R remote relay module to provide additional relay points, and audio/voice components.

2.1.3 System Limitations

System expansion must take into consideration the following:

1. The physical limitations of the cabinet configuration.
2. The electrical limitations of the system power supply.
3. The capacity of the secondary power source (standby batteries).

2.2 System Components



WARNING: UL 9TH EDITION COMPLIANCE

THIS PRODUCT HAS BEEN CERTIFIED TO COMPLY WITH THE REQUIREMENTS IN THE STANDARD FOR CONTROL UNITS AND ACCESSORIES FOR FIRE ALARM SYSTEMS, UL 864 9TH EDITION. OPERATION OF THE NFS2-3030/E WITH PRODUCTS NOT TESTED FOR UL 864 9TH EDITION HAS NOT BEEN EVALUATED AND MAY NOT COMPLY WITH NFPA 72 AND/OR THE LATEST EDITION OF UL 864. THESE APPLICATIONS WILL REQUIRE THE APPROVAL OF THE LOCAL AUTHORITY HAVING JURISDICTION (AHJ).

THIS MANUAL MENTIONS PRODUCTS THAT HAVE RECEIVED UL 864, 9TH EDITION CERTIFICATION, AND ALSO MENTIONS PRODUCTS THAT HAVE NOT. FOR A COMPLETE LIST OF ALL PERIPHERALS THAT CAN BE USED WITH THIS FIRE ALARM CONTROL PANEL (FACP), AND WHICH OF THOSE PERIPHERALS HAVE NOT RECEIVED UL 864, 9TH EDITION CERTIFICATION AND MAY ONLY BE USED IN RETROFIT APPLICATIONS, SEE SECTION 2.5, “COMPATIBLE EQUIPMENT”, ON PAGE 18.

Central Processing Unit (CPU) and Keypad/Display The central processing unit for the NFS2-3030 system can be ordered with a keypad/display (P/N CPU2-3030D) or without a keypad/display (P/N CPU2-3030ND). CPU2-3030D serves as “primary display” version for ULC applications. CPU2-3030ND is intended for use in network applications; LEDs and momentary switches on the printed circuit board mimic those on the keypad to enable operation and troubleshooting at the panel when it is used without a local primary display.

Power supply The main power supply is AMPS-24/AMPS-24E, which provides +24 VDC power and a battery charger for a basic system. Auxiliary power supplies and/or battery chargers are available to customize large systems.

Enclosures Four cabinet sizes are available; doors and backboxes are ordered separately. “A” size backboxes hold one row of modules, “B” size backboxes hold two rows, “C” size backboxes hold three rows, and “D” size backboxes hold four rows. See Section 2.4 “System Cabinets” for basic description. A variety of dress panels, trim rings, and blank modules are available to accompany specific combinations of system equipment; contact Notifier for a complete parts list.

SLC Loops: LCM-320, LEM-320 To provide one SLC loop, connect one LCM-320 to the panel. Connect an LEM-320 to the LCM-320 to provide a second loop. Up to five pairs of modules can be installed on the panel to provide a maximum of ten SLC loops.

Network Connection Connect a wire or fiber version of the NCM or the HS-NCM to provide a connection to the Noti•Fire•Net (network version 5.0 or higher) or High-Speed Noti•Fire•Net.

Annunciators The NFS2-3030 supports ACM-24AT/ACM-48A (and their expanders) with either 64 or 96 points at an address, as well as ACM-16AT/ACM-32A/LDM-32 (and their expanders) with 64 points at an address and Notifier’s other ACS devices. (See Section 2.5 “Compatible Equipment” if looking for specific ACS devices.)

Audio System Voice evacuation applications are documented in the Audio System manuals: *DVC Digital Voice Command Manual*, *DAA2 and Dax Amplifiers Manual*, *DS-DB Digital Series Board Manual*, *DVC-RPU Manual* and the *AA-series Audio Amplifiers Manual*.

2.3 Product Diagram

The control panel electronics are contained on one printed circuit board (PCB) that holds the central processing unit (CPU). The CPU can be purchased with or without keypad and display; (see Section 2.2 “System Components” for P/N details). Connections are identical on both versions. The following figure illustrates the location of the various connections, switches, jumpers and LEDs on the circuit board. See Section 3 “Installation” for more details.

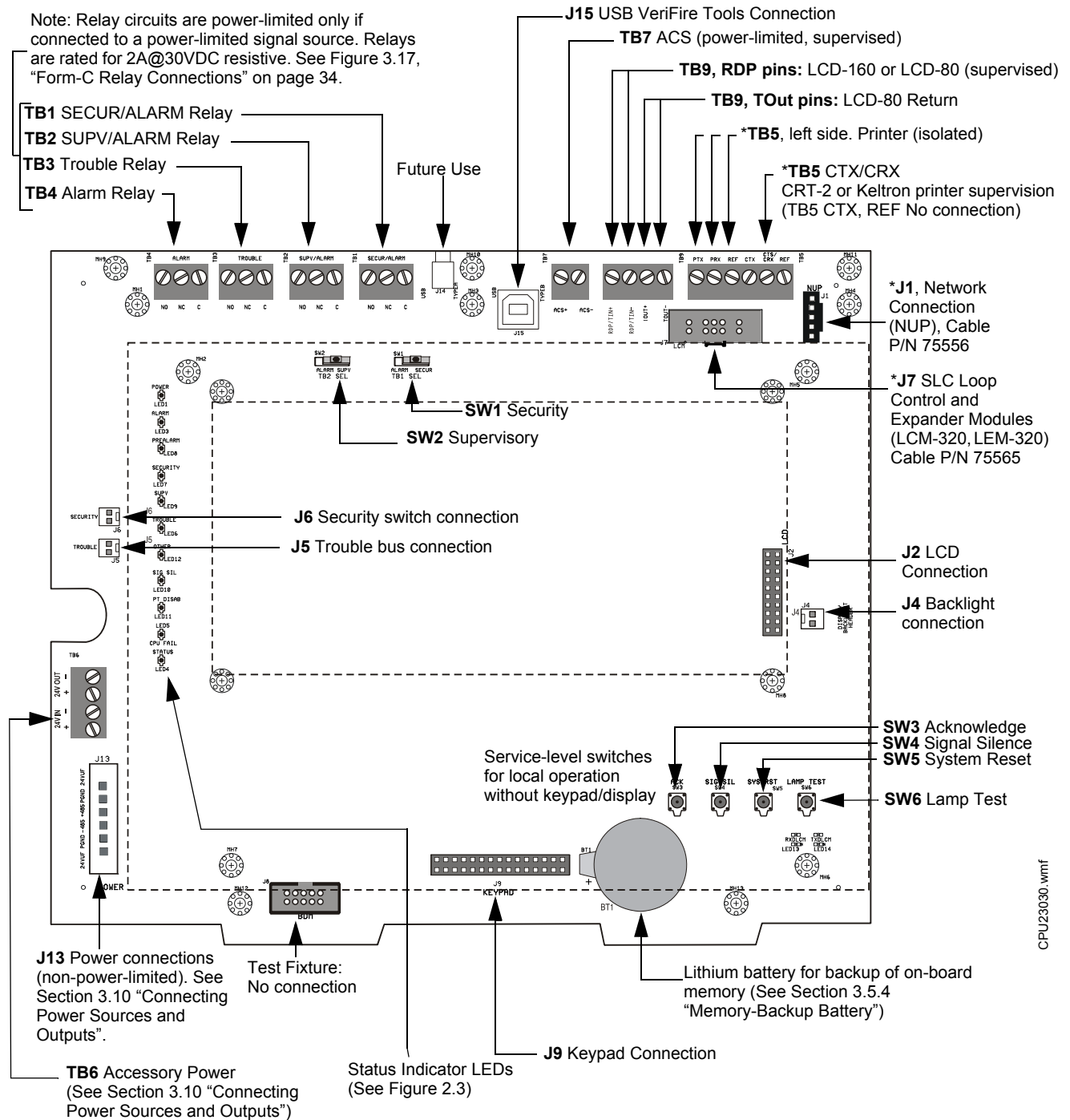

Figure 2.1 CPU Connections

The keyboard/display assembly is shown in Figure 2.2. As shown in Figure 2.3, LEDs on the keyboard/display are repeated on the printed circuit board. This enables operation and troubleshooting when the panel is used without the display assembly.

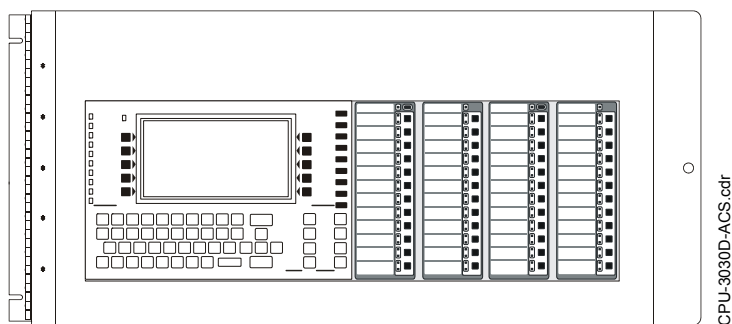

Figure 2.2 CPU2-3030D (Shown with Two Annunciators in DP-DISP)

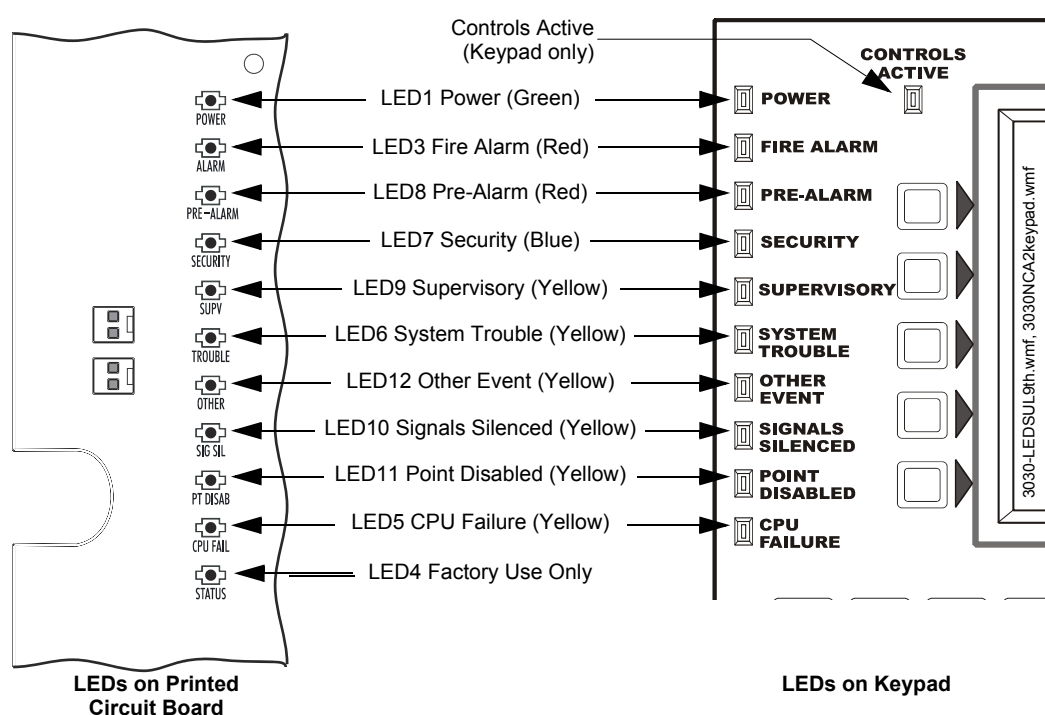

Figure 2.3 Status Indicator LEDs

2.3.1 Main Power Supply

The AMPS-24/E addressable main power supply provides a total of up to 5 A to the CPU. During normal operation, the AMPS-24 can recharge batteries ranging in capacity from 7 to 200 amp-hours. Previous versions of the AMPS-24/E can recharge batteries ranging in capacity from 26 to 200 amp-hours. Previous versions may be identified by the location of the AC power connection on the top edge of the assembly. The AC power connection for the current version is inset from the left edge. The AMPS-24/E also provides:

- Up to 5 A/24 V Auxiliary power
- Up to 0.15 A/5 V Accessory power
- Up to 0.5 A/24 V Accessory power

See Section 3.10, “Connecting Power Sources and Outputs”, on page 34 for basic wiring connections; see the *AMPS-24/E Manual* for complete details.

Refer to the *AMPS-24/E Manual* to determine whether your system requires an auxiliary power supply.

2.4 System Cabinets

The CPU and modules are installed in a CAB-4 series backbox. There are four different sizes available, holding from one to four rows of equipment plus batteries (up to two 26AH batteries). Backboxes are ordered separately from doors. The doors can be mounted on the left or the right side of the cabinet; reversible hinges are provided so that this choice can be made Section 2.5, “Compatible Equipment”, on page 18 in the field. Doors open a full 180 degrees and have locks. Mounting methods include surface-mounting or semi-flush mounting on a wall between 16 inch (406.4 mm) on-center studs. A trim ring option is available for semi-flush mounting.

External measurements for each cabinet backbox are provided below. Refer to *CAB-3/CAB-4 Series Cabinet Installation Document* (shipped with your cabinet) for specific mounting drawings and dimensions.

A-size backbox (one row)	24.125 in (612.78 mm) wide 20.125 in (511.18 mm) tall 5.218 in (132.54 mm) deep Optional trim ring TR-A4	DR-A4
B-size backbox (two rows)	24.125 in (612.78 mm) wide 28.625 in (727.08 mm) tall 5.218 in (132.54 mm) deep Optional trim ring TR-B4	DR-B4, ADDR-B4
C-size backbox (three rows)	24.125 in (612.78 mm) wide 37.250 in (946.15 mm) tall 5.218 in (132.54 mm) deep Optional trim ring TR-C4	DR-C4, ADDR-C4
D-size backbox (four rows)	24.125 in (612.78 mm) wide 45.875 in (1165.23 mm) tall 5.218 in (132.54 mm) deep Optional trim ring TR-D4	DR-D4, ADDR-D4

The CPU and adjacent first-row modules mount in chassis CHS-M3. Additional rows of modules mount in the cabinet using CHS-4, CHS-4N, CHS-4L, or other chassis compatible with CAB-4 series enclosures.

Some additional components available in the CAB-4 series include:

- DP-DISP. An Inner Dress Panel for covering the backbox area surrounding various modules; for use in the top row.
- BMP-1. Blank Module Plate for covering an unused module position. Provides another location for mounting option boards such as TM-4 or NCM/HS-NCM.
- BP2-4. Battery dress panel.
- DP-1B. Blank panel for covering recessed equipment in second, third or fourth rows of backbox.
- ADP-4B. Annunciator dress panel; for use in all but the top row.

For information on audio chassis and dress panels, refer to the *DVC Digital Voice Command Manual*.

2.5 Compatible Equipment

Compatible Notifier and System Sensor equipment that connects directly to the CPU is listed below. These are the most common devices at time of publishing; the most complete list of compatible intelligent SLC loop devices is provided in the *SLC Wiring Manual*; for conventional non-addressable equipment see the *Device Compatibility Document*. These devices are UL and ULC listed unless marked otherwise (in parentheses next to the product). Other control panels and their equipment can also be connected in a network, via Noti•Fire•Net version 5.0 or High-Speed Noti•Fire•Net; refer to the *Noti•Fire•Net Version 5.0 Installation Manual* or the *High-Speed Noti•Fire•Net Installation Manual* for details. Some products are documented in a separate manual; see Section 1.3 “Related Documents”.



WARNING: UL 9TH EDITION COMPLIANCE

THIS PRODUCT HAS BEEN CERTIFIED TO COMPLY WITH THE REQUIREMENTS IN THE STANDARD FOR CONTROL UNITS AND ACCESSORIES FOR FIRE ALARM SYSTEMS, UL 864 9TH EDITION. OPERATION OF THE NFS2-3030/E WITH PRODUCTS NOT TESTED FOR UL 864 9TH EDITION HAS NOT BEEN EVALUATED AND MAY NOT COMPLY WITH NFPA 72 AND/OR THE LATEST EDITION OF UL 864. THESE APPLICATIONS WILL REQUIRE THE APPROVAL OF THE LOCAL AUTHORITY HAVING JURISDICTION (AHJ).

PERIPHERAL DEVICES WERE LISTED UNDER UL 8TH EDITION AND MAY ONLY BE USED IN RETROFIT APPLICATIONS (SEE SECTION 1.2, “UL 864 COMPLIANCE”, ON PAGE 8).

UL 9th Edition Notifier Compatible Equipment

AA-30 30-Watt Audio Amplifier	FMM-1 Monitor Module
AA-100 100-Watt Audio Amplifier	FMM-101 Mini Monitor Module
AA-120 120-Watt Audio Amplifier	FMM-4-20 Monitor Module
ACM-24AT Annunciator Control Module	FSC-851 IntelliQuad Multi-Criteria Smoke Detector
ACM-48A Annunciator Control Module	FSD-751P/RP/PL Duct Detectors
ACM-8R Annunciator Control Module	FSI-751 Ion Detector
ACPS-610 Addressable Charger/Power Supply	FSI-851 Ion Detector
ACT-1 Audio Coupling Transformer	FSM-101 Pull Station Monitor Module
ACT-2 Audio Coupling Transformer	FPJ Fireman's Phone Jack
AEM-24AT Annunciator Expander Module	FRM-1 Relay Module
AEM-48A Annunciator Expander Module	FDM-1 Dual Monitor Module
AKS-1B Annunciator Key Switch	FSL-751 FlashScan VIEW® Laser Detector
AMPS-24/E Addressable Main Power Supply	FSH-751 HARSH™ Photo Detector
APJ-1B Annunciator Phone Jack-G	FSP-751 Photo Detector
B200S/R Intelligent Sounder Base	FSP-851 Photo Detector, listed for use in ducts
BX-501 Intelligent Detectors/Sensors Base	FSP-751T Photo/Thermal Detector
B501 USA Intelligent Detector Base	FSP-851T Photo/heat Detector, listed for use in ducts
B501BH-2 Sounder Base	FST-751 Thermal Detector
B501BHT-2 Temporal Sounder Base	FST-751R Thermal Rate-of-rise Detector
B710LP European Intelligent Detector Base	FST-851 Thermal Detector
B710HD HARSH Detector Base	FST-851R Thermal Rate-of-rise Detector
B224RB Low-profile Relay Base	FST-851H High-temperature Thermal Detector
B224BI Isolator Base for Low-profile Detectors	FZM-1 Zone Module
CMX-1 Addressable Control Module	HS-NCM-MF High-Speed Network Communications Module (Multi-Mode Fiber)
CMX-2 Addressable Control Module	HS-NCM-MFSF High-Speed Network Communications Module (Multi-Mode Fiber to Single-Mode Fiber)
CPX-551 Intelligent Ionization Smoke Detector	HS-NCM-SF High-Speed Network Communications Module (Single-Mode Fiber)
CPX-751 Intelligent Ionization Smoke Detector	HS-NCM-W High-Speed Network Communications Module (Wire)
DAA Series Digital Audio Amplifiers	HS-NCM-WMF High-Speed Network Communications Module (Wire to Multi-Mode Fiber)
DPI-232 Direct Panel Interface	HS-NCM-WSF High-Speed Network Communications Module (Wire to Single-Mode Fiber)
DVC-EM Digital Voice Command	HPX-751 HARSH™ Hostile Environment Smoke Detector
DVC-RPU DVC Remote Paging Unit	ISO-X Loop Fault Isolator Module
DS-AMP Audio Amplifier	LCD-80 Liquid Crystal Display Module
DS-BDA Backup Audio Amplifier	LCD2-80 Liquid Crystal Display Module
DS-XF70V Transformer	LCD-160 Liquid Crystal Display
FAPT-851 (Acclimate Plus™) Combination photo/heat Detector	LCM-320 Loop Control Module
FCM-1NAC Module	LDM-32 Lamp Driver Module
FCM-1-REL Control Module	
FCO-851 Photo/CO Detector	
FCPS-24S6/S8 Field Charger/Power Supply	
FDX-551 Intelligent Thermal Sensor	
FDX-551R Intelligent Thermal Rate-of-Rise Sensor	
FHS Fireman's Handset	
FTM-1 Telephone Module	

LDM-E32 Lamp Driver Module
LDM-R32 Lamp Driver Module
LEM-320 Loop Expander Module
LPX-751 VIEW® Low Profile Laser Detector
MMX-2 Addressable Monitor Module
MMX-101 Addressable Mini Monitor Module
NBG-12LX Series Addressable Manual Pull Station
NCA-2 Network Communications Annunciator
NCM-F Network Communications Module (Fiber)
NCM-W Network Communications Module (Wire)
NCS Network Control Station
N-ELR Assortment ELR Pack with Mounting Plate
ONYXWorks® Workstation Network Monitoring Workstation
PRN-6 80-Column Printer
EOL-CR/CB Assortment ELR Pack with Mounting Plate
R-120 120 Ohm End-of-Line Resistor
R-2.2K 2.2K End-of-Line Resistor
R-27K 27K End-of-Line Resistor
R-470 470 End-of-Line Resistor
R-47K 47K End-of-Line Resistor
A77-716B End-of-Line Resistor Assembly
RA400 Remote Annunciator
RA100Z Remote Annunciator with diode

RKS-S Remote Security Keyswitch (Not ULC-listed)
RPJ-1 Remote Phone Jack
RPT-485F EIA-485 Repeater (Fiber)
RPT-485W EIA-485 Repeater (Wire)
RPT-485WF EIA-485 Repeater (Wire/Fiber)
RM-1 Remote Microphone
RM-1SA Remote Microphone
SCS-8, SCE-8 Smoke Control System
SDX-551 Intelligent Photoelectric Detector
SDX-551TH Intelligent Photoelectric and Thermal Detector
SDX-751 Intelligent Photoelectric Detector
STS-1 Security Tamper Switch (Not ULC-listed)
TM-4 Transmitter Module
UDACT/UDACT-2 Universal Digital Alarm Communicator Transmitter
UZC-256 Universal Zone Coder
VeriFire® Tools Upload/Download Software
XPIQ Quad Intelligent Audio Transponder (Audio Applications)
XP6-C Supervised Control Module
XP6-R Six Relay Control Module
XP10-M Ten Input Monitor Module
XP6-MA Six Zone Interface Module

System Sensor Compatible Equipment

FSB-200S Single-ended beam smoke detector with sensitivity testing.
FSB-200 Single-ended beam smoke detector.

A2143-00 End of Line Resistor Assembly
EOLR-1 End of Line Resistor Assembly

Retrofit Equipment: Compatible Notifier Equipment Listed Under Previous Editions of UL 864

NOTE: The products in this list have not received UL 864 9th Edition certification and may only be used in retrofit applications (see Section 1.2, “UL 864 Compliance”, on page 8).

✓ **ACM-16AT** Annunciator Control Module
 ✓ **ACM-32A** Annunciator Control Module
 ✓ **ACPS-2406** Auxiliary Charger/Power Supply
 ✓ **AEM-16AT** Annunciator Expander Module
 ✓ **AEM-32A** Annunciator Expander Module
 ✓ **AFM-16A** Annunciator Fixed Module
 ✓ **AFM-32A** Annunciator Fixed Module
 ✓ **AMG-1/E** Audio Message Generator
 ✓ **APS-6R** Auxiliary Power Supply
 ✓ **B501BH/B501BHT** Sounder Base
 ✓ **BGX-101L** Addressable Manual Pull Station
 ✓ **CHG-120** Battery Charger
 ✓ **FCPS-24** Field Charger/Power Supply
 ✓ **IPX-751** Advanced Multi-Sensor Intelligent Detector
 ✓ **MMX-1** Addressable Monitor Module
 ✓ **NCA** Network Communications Annunciator

✓ **VS4095** Keltron Printer (Dress plate P-40) (Not ULC-listed)
 ✓ **PRN-4, PRN-5** 80-Column Printers
 ✓ **RFX** Wireless Transmitter (version 2.0 and higher) (Not ULC-listed); SDRF-751 Wireless Photo/Thermal Smoke Detector; 5817CB Wireless Monitor Module
 ✓ **XPIQ** Quad Intelligent Audio Transponder (NAC Applications)
 ✓ **XP5-C** Transponder Control Module
 ✓ **XP5-M** Transponder Monitor Module
 ✓ **XPC-8** Transponder Control Module
 ✓ **XPM-8** Transponder Monitor Module
 ✓ **XPM-8L** Transponder Monitor Module
 ✓ **XPP-1** Transponder Processor
 ✓ **XPR-8** Transponder Relay Module

Section 3: Installation

3.1 Preparing for Installation

Choose a location for the fire alarm system that is clean, dry, and vibration-free with moderate temperature. The area should be readily accessible with sufficient room to easily install and maintain it. There should be sufficient space for cabinet door(s) to open completely.

Carefully unpack the system and inspect for shipping damage. Count the number of conductors needed for all devices and find the appropriate knockouts. (Refer to Section 3.11 “UL Power-limited Wiring Requirements” for selection guidelines.)

Before installing the fire alarm system, read the following:

- Review the installation precautions at the front of this manual.
- Installers should be familiar with the standards and codes specified in Section 1.1 “Standards and Other Documents”.
- All wiring must comply with the National and Local codes for fire alarm systems.
- Do not draw wiring into the bottom 9 inches (22.86 cm) of the cabinet except when using a separate battery cabinet; this space is for internal battery installation.
- Review installation instructions in Section 3.2 “Installation Checklist”.



WARNING: RISK OF IRREPARABLE EQUIPMENT DAMAGE

MAKE SURE TO INSTALL SYSTEM COMPONENTS IN THE SEQUENCE LISTED BELOW. FAILURE TO DO SO CAN DAMAGE THE CONTROL PANEL AND OTHER SYSTEM COMPONENTS.



WARNING: RISK OF IRREPARABLE EQUIPMENT DAMAGE

WEAR A STATIC DISCHARGE STRAP ON WRIST TO PREVENT EQUIPMENT DAMAGE.

3.2 Installation Checklist

The checklist that follows contains references to information included in other manuals; see Section 1.3 “Related Documents” for document part numbers.

Task	Refer to:
1. Mount the cabinet backbox to the wall.	Section 3.3 “Mounting a Cabinet”
2. Attach CPU to chassis	Section 3.5 “Attaching the CPU & Chassis”
3. Attach option boards (e.g. SLC loop modules, network communications modules, and other devices of the same size) to chassis.	<ul style="list-style-type: none"> • Section 3.6 “Attaching Option Boards” • Section 3.7 “Connecting the Network Communications Module” • Installation document for the specific device
4. Attach chassis to backbox as appropriate for system design	Section 3.4 “Laying Out Equipment in Cabinet and Chassis”
5. Wire relays	Section 3.9 “Form-C Relays on the CPU”
6. Attach & wire other system components	
<input type="checkbox"/> Audio/Voice equipment	<i>DVC Digital Voice Command Manual, DAA Digital Audio Amplifiers Manual, DVC-RPU Manual, AA-series Audio Amplifiers Manual</i>
<input type="checkbox"/> Annunciators and other ACS devices	Installation document for the specific device (such as <i>ACS Manual, ACM-8R Manual, etc.</i>)

Table 3.1 Installation Checklist (1 of 2)

Task	Refer to:
<input type="checkbox"/> Remote Data Port devices	LCD-160 Manual
<input type="checkbox"/> Printer or other output device(s)	Section 3.14 “Installing Printers”
<input type="checkbox"/> Network devices	<i>Noti•Fire•Net Version 4.0 & Higher Manual/High-Speed Noti•Fire•Net Manual</i> , and/or Installation document for specific device(s)
7. Wire the Signaling Line Circuits (Notification Appliance Circuits and Initiating Device Circuits)	Section 3.15 “Wiring a Signaling Line Circuit (SLC)” and the SLC Wiring Manual
8. Calculate the proper battery rating.	Main Power Supply Manual
9. Install main power supply & batteries in separate enclosure. Run cable to main & optional power supplies, DC power outputs, relays, etc.	<ul style="list-style-type: none"> • Section 3.10 “Connecting Power Sources and Outputs” • Section 3.11 “UL Power-limited Wiring Requirements”
<div style="border: 1px solid black; padding: 5px;">  WARNING: DO NOT ACTIVATE POWER AT THIS TIME. DO NOT CONNECT BATTERIES. </div>	
<input type="checkbox"/> Main power supply.	<ul style="list-style-type: none"> • <i>Main Power Supply Manual</i> • <i>BB-100/200 Cabinet Installation Instructions</i>
<input type="checkbox"/> Auxiliary power supply and/or external battery charger	Auxiliary power supply manuals and/or battery charger manuals. Note: If using multiple power supplies with one set of batteries, refer to main power supply manual for connection requirements.
10. Check that all mounting holes are secured to insure a proper Earth Ground connection.	
11. Connect wire shielding to Earth Ground.	
12. Remove insulator from lithium battery on CPU	Section 3.5.4 “Memory-Backup Battery”
13. Apply AC power to the control panel by placing the external circuit breaker to the ON position. Do NOT connect batteries until AC power is checked (see next step).	
14. Check AC power.	Section 3.10.3 “Checking AC Power”
15. Connect the batteries using interconnect cable as described in power supply manual.	
16. Install the dress panels, doors and covers.	<i>CAB-3/CAB-4 Series Cabinet Installation Document</i>
17. Program the control panel.	Programming Manual.
18. Field test the system.	Section 5 “Testing the System”

Table 3.1 Installation Checklist (2 of 2)

3.3 Mounting a Cabinet

This section provides instructions for mounting the CAB-4 Series backbox to a wall. Follow these guidelines when mounting the backbox:

- Locate the backbox so that the top edge is 66 inches (1.6764 m) above the surface of the finished floor.
- Allow sufficient clearance around cabinet for door to swing freely. (See Section 2.4 “System Cabinets”.)
- Use the four holes in the back surface of the backbox to provide secure mounting (See Figure 3.1).
- Mount the backbox on a surface that is in a clean, dry, vibration-free area.

**CAUTION:**

UNLESS YOU ARE FAMILIAR WITH THE PLACEMENT OF COMPONENTS WITHIN THIS BACKBOX, ONLY USE THE KNOCKOUT LOCATIONS PROVIDED FOR CONDUIT ENTRY.

Follow the instructions below.

1. Mark and pre-drill holes for the top two keyhole mounting bolts.
2. Select and punch open the appropriate knock-outs. (For selection guidelines, see Section 3.11 “UL Power-limited Wiring Requirements”.)
3. Using the keyholes, mount the backbox over the two screws.
4. Mark the location for the two lower holes, remove the backbox and drill the mounting holes.
5. Mount the backbox over the top two screws, then install the remaining fasteners. Tighten all fasteners securely.
6. Feed wires through appropriate knockouts.
7. Install CPU and other components according to this section, before installing hinges and door (see *CAB-3/CAB-4 Series Cabinet Installation Document*).

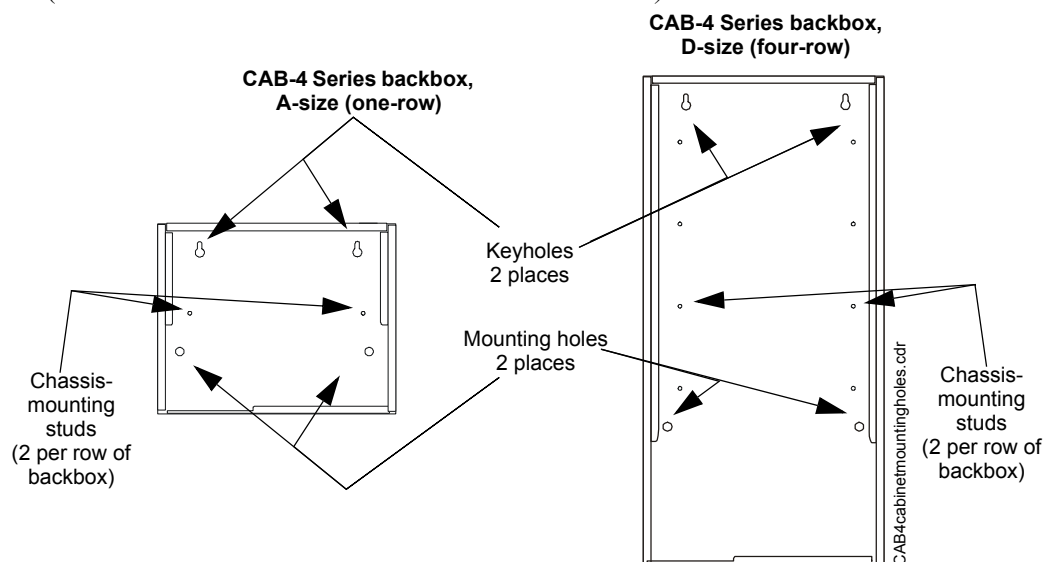

Figure 3.1 Backbox-Mounting Holes and Chassis-Mounting Studs

3.4 Laying Out Equipment in Cabinet and Chassis

The NFS2-3030 allows for flexible system design. It mounts in a CAB-4 series backbox using either CHS-M3 or CA-2. Follow these guidelines when deciding where to locate equipment in the backbox. There are four basic positions available on a chassis; the number of layers that can be mounted in each position depends on the chassis model and the module size.

■ CHS-M3

The CPU mounts in chassis CHS-M3 in the top row of the cabinet. The CPU and its optional display occupy the left half of the chassis (positions 1 and 2, see Figure 3.2).

Positions 3 and 4 of CHS-M3 can hold up to four layers of equipment including option boards and annunciators (door-mounted in front of CHS-M3). See Figure 3.4 for possible configurations of these four layers.

The BMP-1 Blank Module Plate covers unused positions and also provides a location to door-mount some option boards (see *BMP-1 Product Installation Drawing* for details).

■ CA-2

The CA-2 Audio Chassis assembly includes hardware to mount an audio command center installation in two rows of a CAB-4 backbox. Equipment will be located in the chassis as shown in Figure 3.6. See Section 3.5.2, “Mounting in the CA-2 Audio System Chassis” and the *CA-2 Installation Document*.

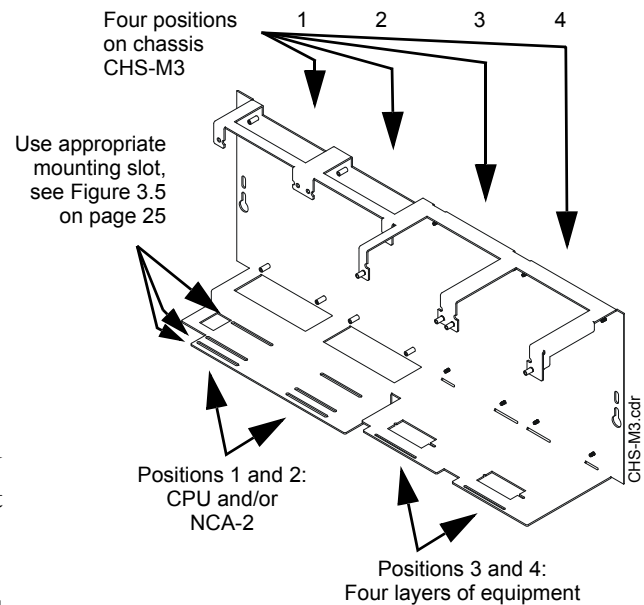

Figure 3.2 Chassis CHS-M3

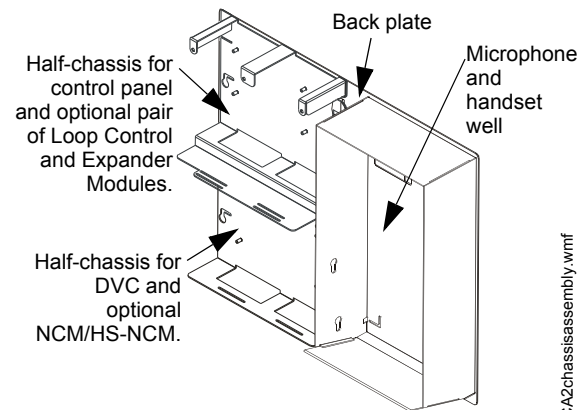
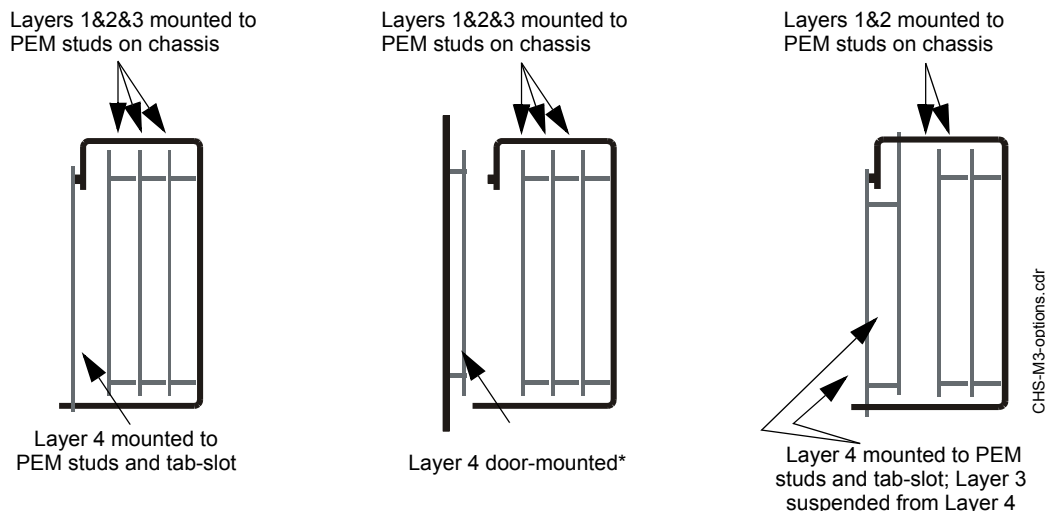

Figure 3.3 CA-2 Audio Chassis Assembly

■ Options for Mounting Other Equipment



*Note: If CHS-4N is used, door-mounting is only for use with ACM-24AT and ACM-48A series annunciators.

**Figure 3.4 Configuring Equipment in Chassis (Side View):
Positions 3 and 4 of CHS-M3, All 4 Positions of CHS-4N**

Second, third, and fourth rows of equipment use any chassis compatible with CAB-4 series backboxes, such as CHS-4N (shipped as part of CHS-4MB) or CHS-4L. Refer to the *CAB-3/CAB-4 Series Cabinet Installation Document* for a complete list. Some equipment (such as annunciators) can be door-mounted as shown in Figure 3.9; refer to your equipment’s documentation for instructions.

Examples of option boards are LCM-320, LEM-320, wire and fiber versions of the NCM and HS-NCM, TM-4, and DPI-232; see Section 3.6 “Attaching Option Boards”. The documentation shipped with your equipment may also contain device-specific instructions.



NOTE: It is recommended that system design take into consideration the UL requirements for minimum separation of power-limited and non-power-limited wiring; for example, having all non-power-limited circuits grouped in one area of the cabinet (see Section 3.11 “UL Power-limited Wiring Requirements” and your power supply manual).

3.5 Attaching the CPU & Chassis

Note for CPU2-3030D. Due to the difficulty of reaching under the keypad, it may be convenient to remove the insulator from the lithium memory-backup battery before mounting the CPU into the chassis. See Section 3.5.4 “Memory-Backup Battery”.

3.5.1 Mounting in CHS-M3

Mount CPU into positions 1 and 2 of CHS-M3 as follows; equipment may be mounted to the chassis before or after the chassis is mounted in the backbox. Some equipment may be door-mounted directly in front of the CPU; see Section 3.4 “Laying Out Equipment in Cabinet and Chassis” and the manual shipped with the other device.

1. Attach four stand-offs to chassis as shown in Figure 3.5.
CPU2-3030D (with keypad/display) requires the longer stand-offs: 1.5 inch (38.1 mm);
CPU2-3030ND (without keypad/display) requires the shorter stand-offs: 0.25 inch (6.35 mm)
2. Slide circuit-board tabs into slots on chassis as shown in Figure 3.5.

- Place the board over the stand-offs so that mounting holes line up with those on the chassis. Secure all stand-offs with screws provided.

CPU standoffs at Positions 1 and 2:
1.5 inch (38.1 mm) for use with CPU2-3030D
or 0.25 inch (6.35 mm) for use with CPU2-3030ND

Chassis-mounting slots

CPU2-3030ND
(without keypad/display)

CPU2-3030D
(with keypad/display)

NCA-2
(see *NCA-2 Manual*)

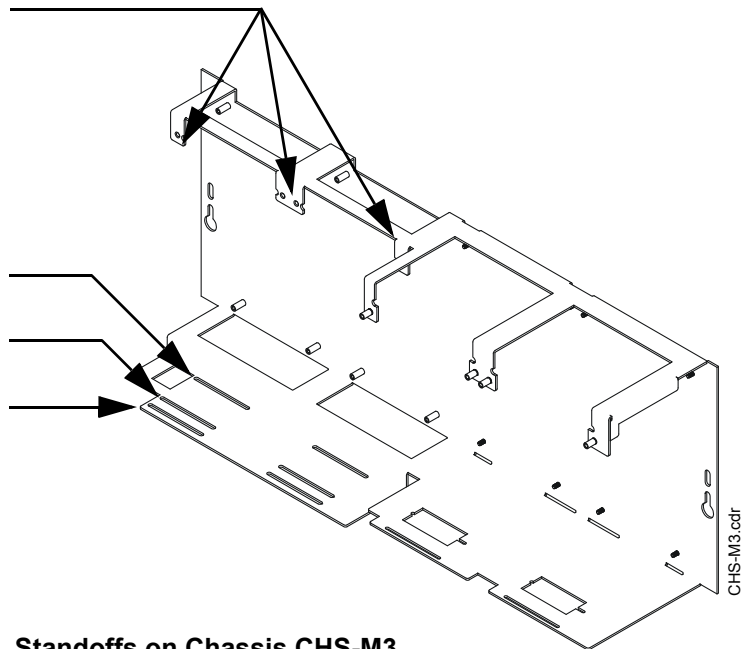

Figure 3.5 Standoffs on Chassis CHS-M3



CAUTION:

IT IS CRITICAL THAT ALL MOUNTING HOLES OF THE FIRE ALARM CONTROL PANEL ARE SECURED WITH A SCREW OR STAND-OFF TO INSURE CONTINUITY OF EARTH GROUND.

3.5.2 Mounting in the CA-2 Audio System Chassis

The NFS2-3030 will mount into the CA-2 chassis assembly—along with a DVC, microphone and optional telephone handset—as part of an audio command center installation.

The CA-2 is a two-row assembly consisting of

- a back plate that attaches to the backbox
- two half-chassis, each of which takes up the left half of a backbox row
- a microphone and telephone handset well
- a microphone

CA-2 can also mount TELH-1, an optional telephone handset.

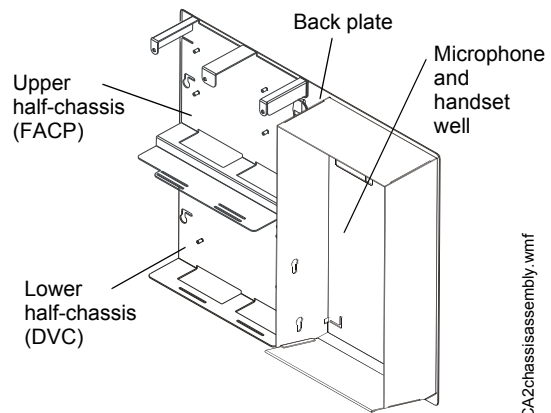

Figure 3.6 CA-2 Chassis Assembly

The NFS2-3030 mounts in the upper half-chassis. (Refer to Figure 3.6 and Figure 3.7.) If first mounting an optional LCM-320/LEM-320 pair behind the FACP, refer to Section 3.8.2, “Audio Applications with Chassis CA-2”. Mount the NFS2-3030 to its half-chassis without removing the half-chassis from the back plate. Refer to “Memory-Backup Battery” on page 26 for removal of insulator.

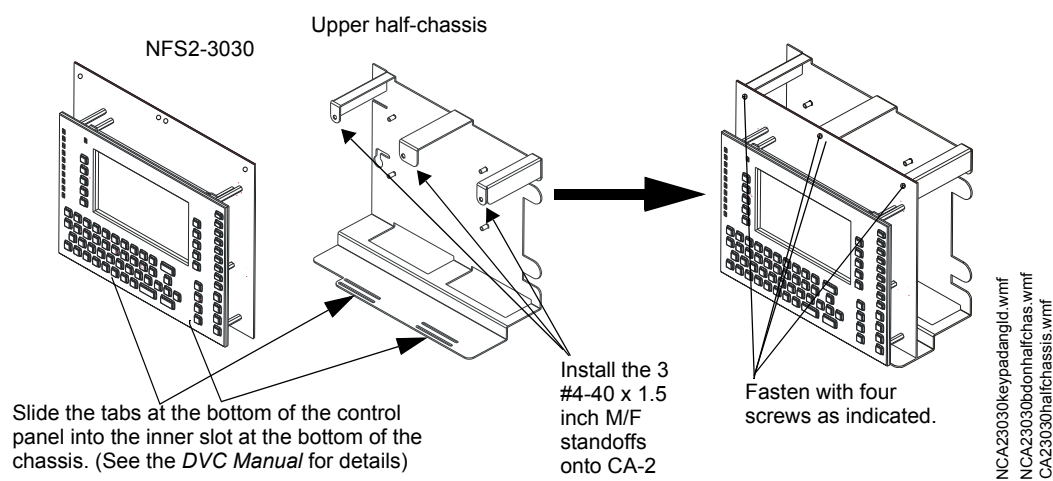

Figure 3.7 Mounting the NFS2-3030 onto the CA-2 Half-chassis

Refer to the *DVC Manual* for installation of the DVC, microphone and handset into the CA-2.

3.5.3 Mounting Chassis in Backbox

■ CHS-M3

Align chassis-mounting slots with chassis-mounting studs (see Figure 3.1 and Figure 3.5 for locations). Secure with nut & lock-washer provided with chassis.

■ CA-2

Install all equipment into the CA-2 and attach to the CA-2 backplate before the chassis assembly is attached to the backbox. Align four backplate-mounting slots with backbox’s chassis-mounting studs. Secure with nut and lock-washer provided with chassis. For details, see the instructions in the *CA-2 Installation Document*.

3.5.4 Memory-Backup Battery

The lithium battery on the CPU provides backup of the CPU’s on-board memory during power loss. The CPU ships with an insulator to prevent the battery from discharging. To preserve the battery, the insulating tube should be left in place as long as possible before applying AC power.

If the insulator is *not* removed before applying AC power, the control panel will show a trouble situation.

This battery’s shelf-life should exceed 10 years, but if for some reason it fails, the control panel will show a trouble when powered up. To replace the lithium battery:

1. Make a full backup of all system settings to prevent loss of all programming data.
2. Disconnect all power sources.

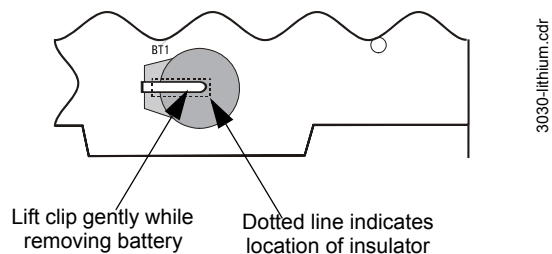

3. *CPU2-3030D only*: Disconnect wiring and remove CPU2-3030D from backbox (3 screws at top, lift board tabs out of slot) and remove keypad (4 screws on back, LCD display stays attached).
4. Remove battery from under clip (use fingers, because screwdriver could damage components) and insert new battery.

**CAUTION:**

THE BATTERY USED IN THIS DEVICE MAY PRESENT A RISK OF FIRE OR CHEMICAL BURN IF MISTREATED.

DO NOT RECHARGE, DISASSEMBLE, HEAT ABOVE 212°F (100°C), OR INCINERATE.

REPLACE BATTERY WITH RAYOVAC LITHIUM 3 VOLT BR2335 OR EQUIVALENT ONLY. USE OF ANOTHER BATTERY MAY PRESENT A RISK OF FIRE OR EXPLOSION.

5. *CPU2-3030D only*: Replace keyboard, reinstall CPU2-3030D into chassis, and reconnect wiring.
6. Follow system power-up procedures.
7. Dispose of used battery promptly. Keep away from children. Do not disassemble and do not dispose of in fire.

3.6 Attaching Option Boards

If installing option boards into a CAB-4 Series backbox, mount & connect those boards at this time. This section contains general instructions for mounting an option board; see the documentation that shipped with your board for any product-specific instructions.

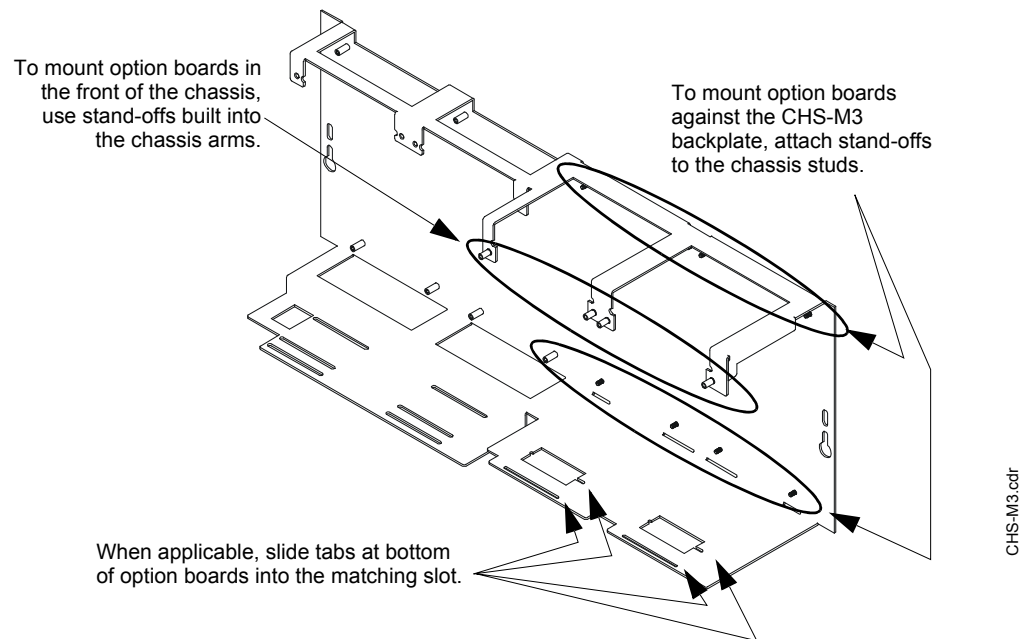

For mounting in CHS-4L, see Figure 3.14

Figure 3.8 Mounting Option Boards in CHS-M3

As described in Section 3.4 “Laying Out Equipment in Cabinet and Chassis”, up to eight option boards can be mounted in CHS-M3 to the right of the CPU; additional modules can be mounted in other chassis.

There are no slots in the first (back) two layers, but option boards with tabs (such as NCM-W) will still fit in those positions.

Option boards can be door-mounted behind a single-space blank plate (see Figure 3.9), and mounted in any CAB-4 compatible chassis.

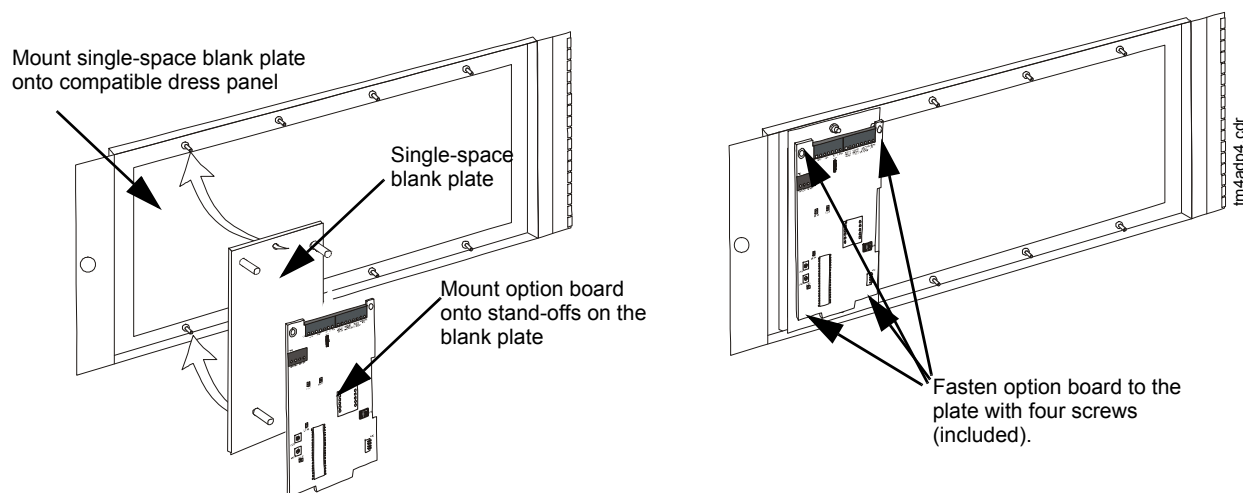

Note: Mounting instructions for option boards are the same in various dress panels.

Figure 3.9 Door-Mounting Option Boards with a Single-space Blank Plate

Mounting procedures

1. Install four 1 inch (25.4 mm) stand-offs onto the chassis as shown in Figure 3.8.
2. Place the first option board over the stand-offs so that holes line up.
3. If no more option boards will be mounted in that position, securely fasten all stand-offs with screws (provided with module). If mounting a second or third option board, attach another layer of stand-offs and repeat steps 2-3. **Note:** Set the switches on an option board before mounting another layer in front of it.
4. If mounting a pair of SLC loop modules, refer to Section 3.8 “Connecting the Loop Control and Expander Modules” and to Section 3.8.5 “Installing a Multi-layer Module into the Chassis”.
5. For the top (fourth) layer of option boards, slide the tab at the bottom of the board into the slots on the chassis, and lay the board back onto the top of the chassis so that the studs line up with mounting holes on the option board. Securely fasten all stand-offs with screws provided with module.
6. If mounting the option board behind a blank module plate in a dress plate or annunciator backbox, see Figure 3.9 and the *BMP-1 Product Installation Drawing*. This dress plate is suitable for option boards, which do not need to be visible or accessible when the door is closed.
7. If mounting a pair of loop control/expander modules, see Section 3.8 “Connecting the Loop Control and Expander Modules”.



NOTE: Mounting two pairs of loop-control and -expander modules in one chassis position may cause intermittent electrical interference. If this occurs, move one pair to a separate chassis position.

3.7 Connecting the Network Communications Module

If networking two or more control panels (or network control annunciators), each one requires a Network Communications Module; a wire version and a fiber version are available. The wire and fiber versions on the NCM or HS-NCM can be installed in any option board position described in Section 3.6, “Attaching Option Boards”. The preferred positions are immediately to the right of the main circuit board, or in the row below. If the system uses Digital Voice Command, the DVC’s wire or fiber version of the NCM or HS-NCM can be mounted behind the DVC on its chassis; see the *DVC Manual* for instructions. If using the Digital Audio Amplifier, the DAA’s wire or fiber version of the NCM or HS-NCM can be mounted on the DAA chassis; see the *DAA Manual* for instructions.

1. Mount the NCM or HS-NCM in the selected position. If another board is going to be mounted in the slot immediately in front of it, use stand-offs to secure it in place. Otherwise use the screws provided.
2. Connect J1 on the CPU to J3 on the NCM or J6 on the HS-NCM using the network cable provided (P/N 75556). Do not connect two NCMs via NUP ports (aka NUP to NUP).
3. **When installing an NCM:** Connect Channel A and/or Channel B as described in the *NCM Installation Document*.
When installing a HS-NCM: Connect Channel A to Channel B as described in the *HS-NCM Installation Document*.



NOTE: See the *Noti•Fire•Net Version 5.0 & Higher Manual* and the *NCM Installation Document* or the *High-Speed Noti•Fire•Net Manual* for system configuration information. See the *BMP-1 Product Installation Drawing* if considering mounting the module (wire version) behind blank module plate in a dress plate or annunciator backbox.



NOTE: Over-bending fiber-optic cable can damage it. Do not exceed a 3 inch (7.62 cm) minimum bend radius.



NOTE: NCM hardware is not compatible with HS-NCM hardware and should not be mixed on the same network.

3.8 Connecting the Loop Control and Expander Modules

3.8.1 Mounting Instructions

Mount loop control and expander modules within the cabinet with the CPU. Two typical mounting positions are adjacent to the panel or in the row immediately below it. (DVC applications in the CA-2 chassis have specific requirements; see 3.8.2, "Audio Applications with Chassis CA-2" at the end of this section.) Follow the basic chassis-mounting instructions given for option boards. Loop-expander modules are mounted first; Loop-control modules are mounted on top of those. Alternately, loop-control and loop-expander modules can be attached to each other and mounted as a pair to the chassis. See Figure 3.12 for connection instructions, connector locations and stand-off lengths.

To suspend a pair of modules in the third and fourth layer of CHS-M3, follow the instructions given in Section 3.8.5 “Installing a Multi-layer Module into the Chassis”. If using loop control and expander modules in CHS-4L see Figure 3.14.



NOTE: Mounting two pairs of loop control and expander modules in one chassis position may cause intermittent electrical interference. If this occurs, move one pair to a separate chassis position.

After all loop-control and loop-expander modules are mounted in the cabinet, connect the SLC loops to TB1 on each loop-control and loop-expander module as shown in Figure 3.16. Daisy-chain the loop-control modules as shown in Figure 3.15. The ribbon-cable connection runs from header J7 on the CPU to header J1 (“Data in”) on the first loop-control module, from J3 (“Data out”) on that unit to J1 on the next unit in the chain, and likewise for up to five loop-control modules. Each module should be assigned a unique SLC loop number (see below); loop number does not need to match the module’s location in this daisy-chain.

FlashScan devices can operate in either FlashScan or, for retrofit applications, CLIP mode. Each LCM-320 or LEM-320 running a FlashScan SLC can support up to 159 detectors and 159 modules. CLIP loops are limited to 99 detectors and 99 modules. These and other capacity restrictions for CLIP mode loops are discussed in Section 3.15 “Wiring a Signaling Line Circuit (SLC)”. Refer to the *SLC Wiring Manual* for wiring requirements and specific details.



CAUTION:

DO NOT PROGRAM MORE THAN 99 ADDRESSES ON A CLIP-MODE SLC LOOP, BECAUSE THIS WILL SLOW THE SYSTEM DOWN AND COMPROMISE THE RESPONSE TIME OF THE PANEL TO DISPLAY OFF-NORMAL EVENTS.

3.8.2 Audio Applications with Chassis CA-2

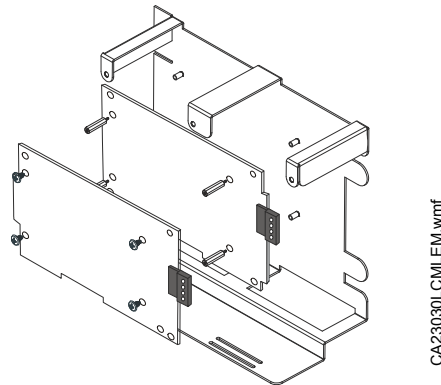

Figure 3.10 Mounting First Pair of Loop Control and Expander Modules in CA-2

The first pair of loop control and expander modules should be mounted behind the DVC as shown in Figure 3.10, or in the row immediately below the CA-2. Any additional loop control and expander modules should be mounted in the row immediately below the CA-2.

3.8.3 Setting SLC Loop Number

Assign a unique SLC loop number to the loop control module by setting SW1 on the module to 1, 3, 5, 7, or 9. The loop expander module which is mounted behind this loop control module will be assigned the next-higher even number. For example, if the LCM-320 is set to loop number 5, the LEM-320 mounted to it will be set to loop number 6.

3.8.4 Enabling External Power Supervision

With LCM-320 revision 2.0 and higher, some type codes have external power supervision built into the software; see Section 4.2 “Devices Requiring External Power Supervision” for details.

3.8.5 Installing a Multi-layer Module into the Chassis

Follow the instructions illustrated in Figure 3.13 to install a pair of loop control/expander modules into CHS-4N or CHS-M3. See Figure 3.14 to install loop control/expander modules in CHS-4L.

1. Angle the module into the chassis so that the upper end of the rear board (or boards) fits into the top slot.
2. Bring the module back down so that the lower board edges slip into the bottom slots.
3. Secure the module to the chassis with the two module screws. Tighten securely.
4. Connect the ribbon cable to the module.

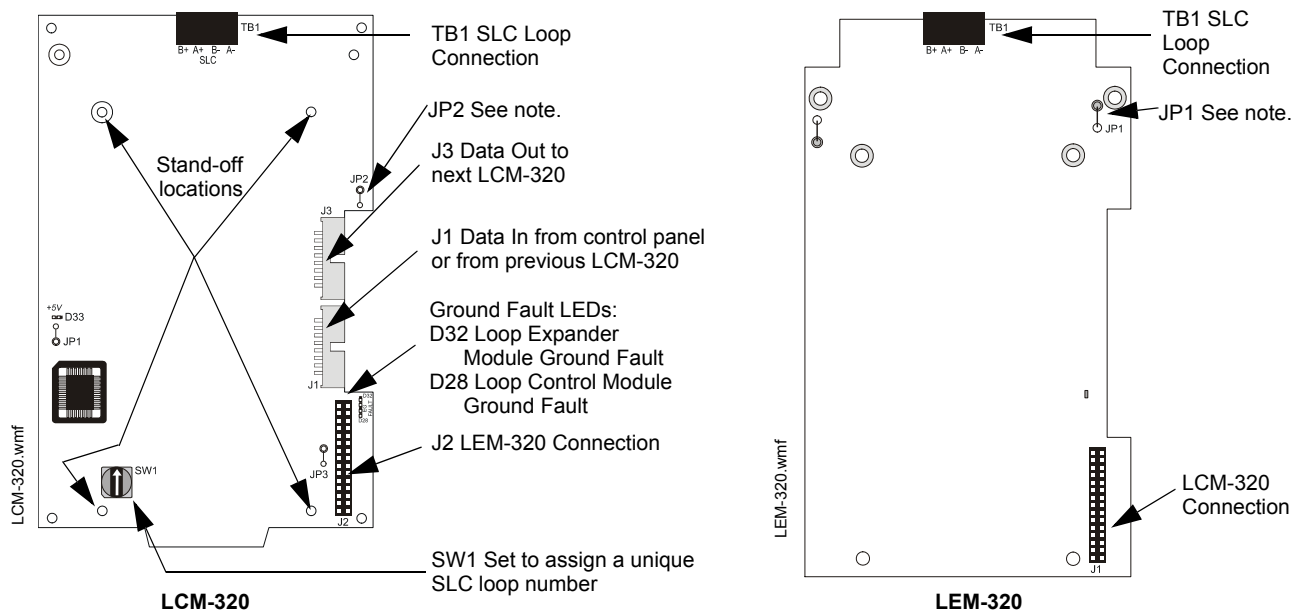

Note: Do not cut any jumpers on the LCM-320 or LEM-320.

Figure 3.11 LCM-320 and LEM-320 Diagram



WARNING: RISK EQUIPMENT DAMAGE.
USE SPECIFIED STAND-OFF MOUNTING LOCATIONS ONLY. SEE FIGURES 3.11 AND 3.12. DO NOT USE CORNER HOLES FOR INSTALLATION PURPOSES.

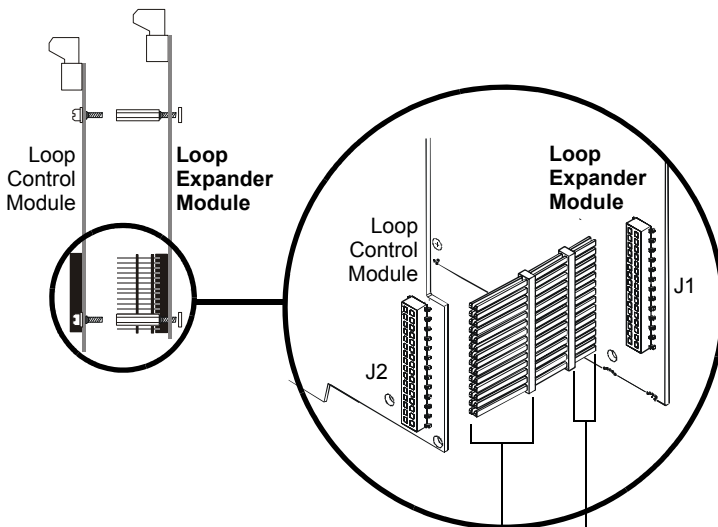

The long-pin end plugs directly into the back of the Loop Control Module board.
The short-pin end plugs directly into the top of the Loop Expander Module plug.

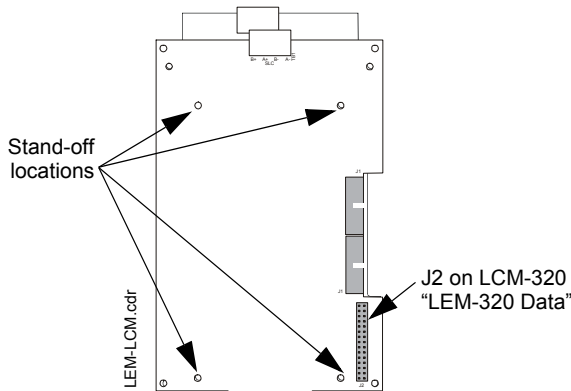

Loop Expander Module mounted behind Loop Control Module



CAUTION: IF THE STACKER-CONNECTOR IS INSTALLED UPSIDE-DOWN, THE SHORT-PIN END OF THE PLUG CAN FAIL TO MAKE A SECURE CONNECTION WHEN PLUGGED THROUGH THE LOOP CONTROL MODULE.

Figure 3.12 Connecting Loop Control Modules with Loop Expander Modules

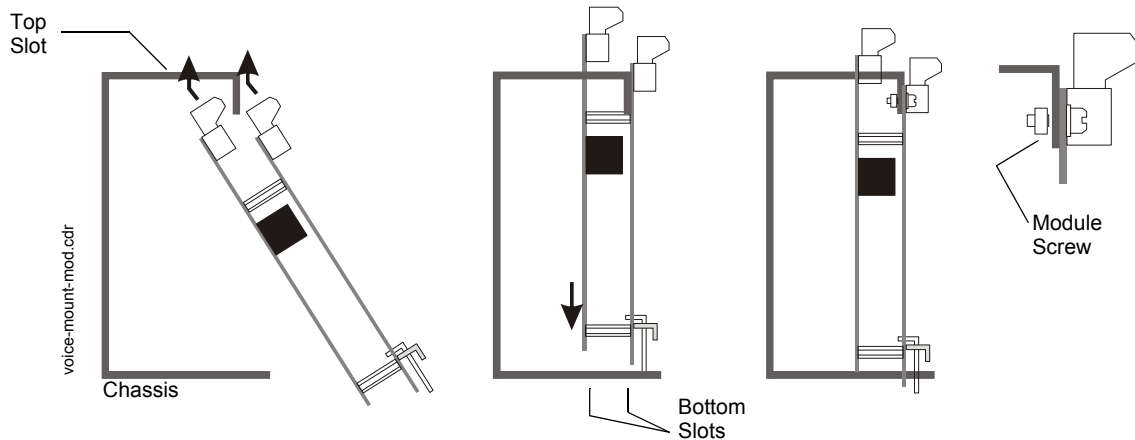

Figure 3.13 Inserting a Two-Layer Module into CHS-4N or CHS-M3 Chassis



NOTE: Depending on system components, clearance may be tight. Do not force modules! Move the assembly around gently until you find the angle where components and mounting studs pass each other without scraping together.

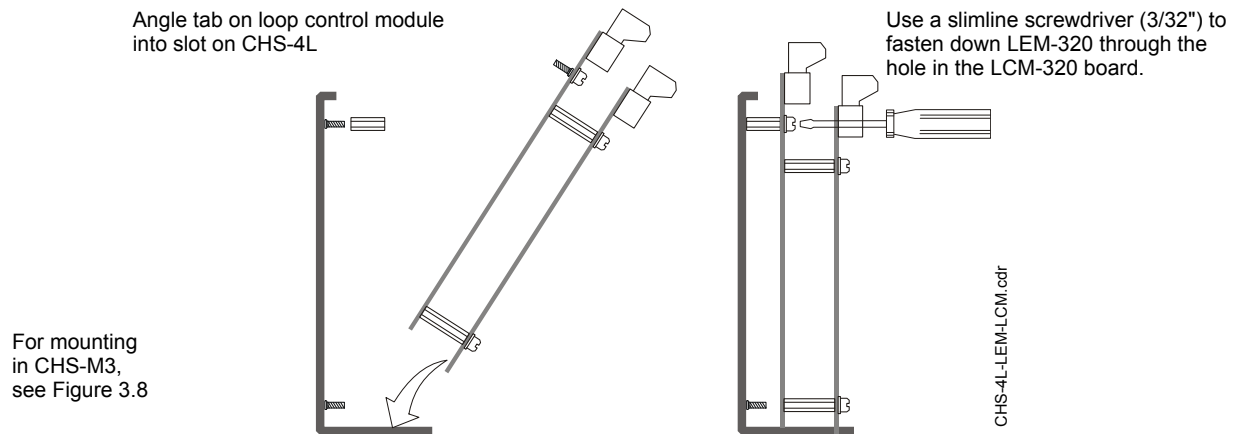

Figure 3.14 Inserting Pair of Loop Control and Expander Modules into CHS-4L

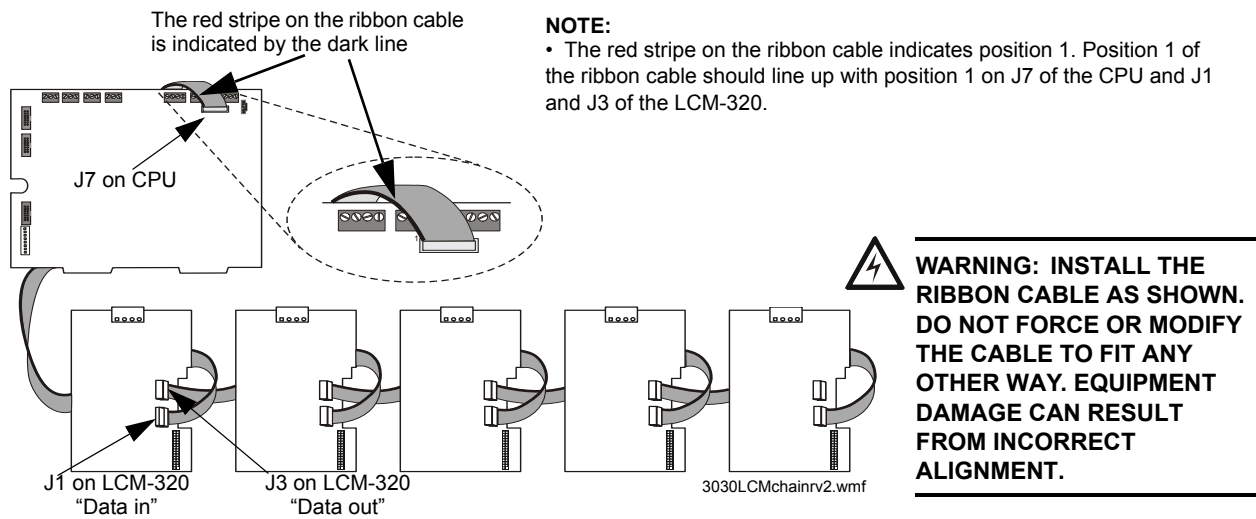

Figure 3.15 Connecting Multiple Pairs of Loop Control and Expander Modules

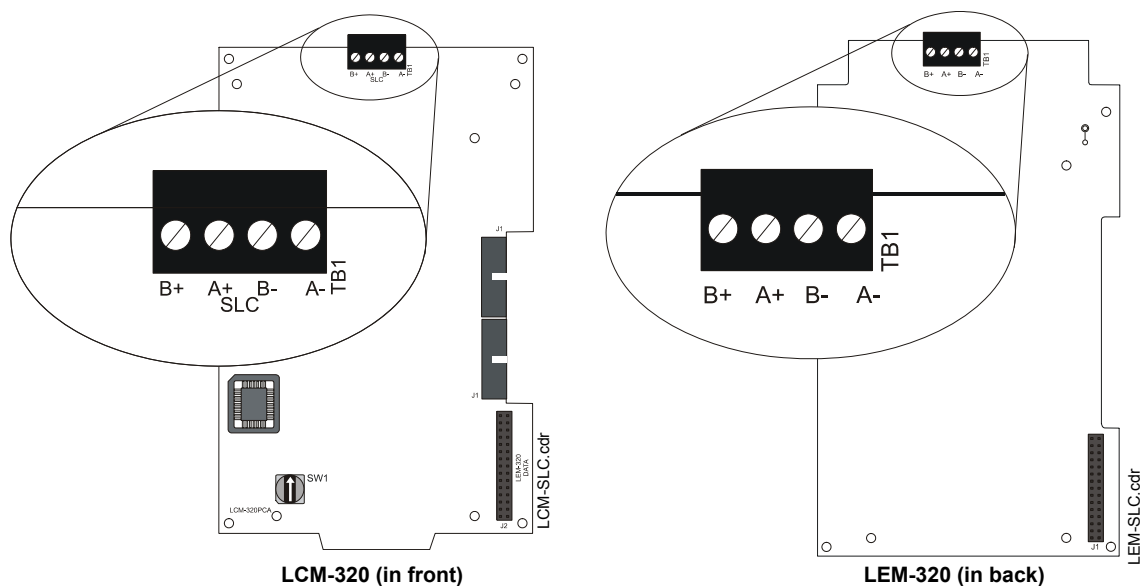

Figure 3.16 SLC Loop Connections on Loop-Control and Loop-Expander Modules

3.9 Form-C Relays on the CPU

The panel provides a set of Form-C relays. These are rated for 2 A at 30 VDC (resistive):

- Alarm - TB4
- Trouble - TB3
- Supervisory - TB2
- Security - TB1

The Supervisory and Security contacts can also be configured as Alarm contacts by setting switches SW1 and SW2 away from the factory default positions shown in Figure 3.17.

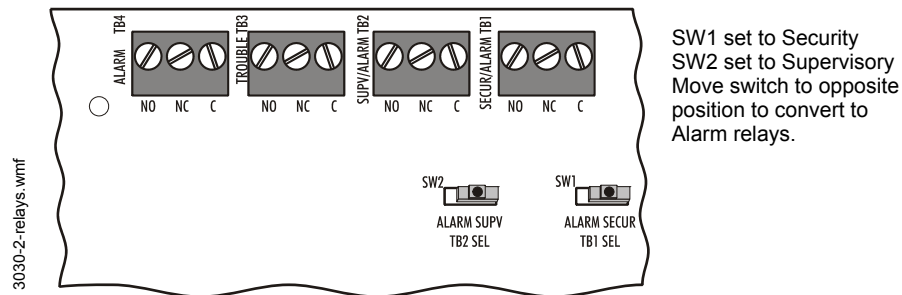

Figure 3.17 Form-C Relay Connections

3.10 Connecting Power Sources and Outputs



WARNING:

REMOVE ALL POWER SOURCES TO EQUIPMENT WHILE CONNECTING ELECTRICAL COMPONENTS. LEAVE THE EXTERNAL, MAIN POWER BREAKER OFF UNTIL INSTALLATION OF THE ENTIRE SYSTEM IS COMPLETE.



WARNING:

SEVERAL SOURCES OF POWER CAN BE CONNECTED TO THE CONTROL PANEL. BEFORE SERVICING THE CONTROL PANEL, DISCONNECT ALL SOURCES OF INPUT POWER *INCLUDING THE BATTERY*. WHILE ENERGIZED, THE CONTROL PANEL AND ASSOCIATED EQUIPMENT CAN BE DAMAGED BY REMOVING AND/OR INSERTING CARDS, MODULES, OR INTERCONNECTING CABLES.

3.10.1 Overview

Complete all mounting procedures and check all wiring before applying power. Electrical connections include the following:

- **Primary power source.** +24VDC, delivered through AMPS-24/AMPS-24E main power supply. If AMPS-24/E is mounted in a separate cabinet, power-supply wiring must be in conduit (for cabinet placement information see Section 3.4 “Laying Out Equipment in Cabinet and Chassis” and the *AMPS-24/E Manual*).
- **Secondary power source.** +24 VDC from batteries, installed in the control panel (or in an optional battery cabinet). Secondary (battery) power is required to support the system during loss of primary power.
- **External power sources.** +24VDC auxiliary power supplies that are UL/ULC-listed for fire protective service.

- **Accessory power for peripheral devices.** TB6 on the CPU draws power from primary, secondary and external sources to pass +24 VDC power to devices within the same enclosure as the CPU. If those devices have outputs, the outputs must be power-limited. Power rating is limited by the AMPS-24/24E primary power source, which is +24VDC and 5 Amps max. TB3 on the AMPS-24 (TB6 on previous AMPS-24/E versions) provides a secondary Accessory power source. Refer to the Power Supplies Calculations Table of the *AMPS-24/24E Manual* for further details.



NOTE: The CPU ships with an insulator to prevent its lithium battery from discharging. To preserve the battery, this insulator should be left in place as long as possible before applying AC power. Some installers may find it convenient to remove the insulator before mounting all equipment.



NOTE: If using multiple power supplies with one set of batteries, refer to main power supply manual for connection requirements.

3.10.2 Connecting the Power Supply

Connect J13 Power on the CPU to TB1 on AMPS-24/E with Cable 75637 (see Figure 3.18). This cable is 20 feet long, and must run in conduit between the backbox containing the fire alarm control panel and the backbox containing the AMPS-24/E. See *AMPS-24/E Manual* for full details and installation precautions.

In order to conserve batteries, connect AC power and check it before connecting batteries. Follow the procedures specified in the power supply manual.

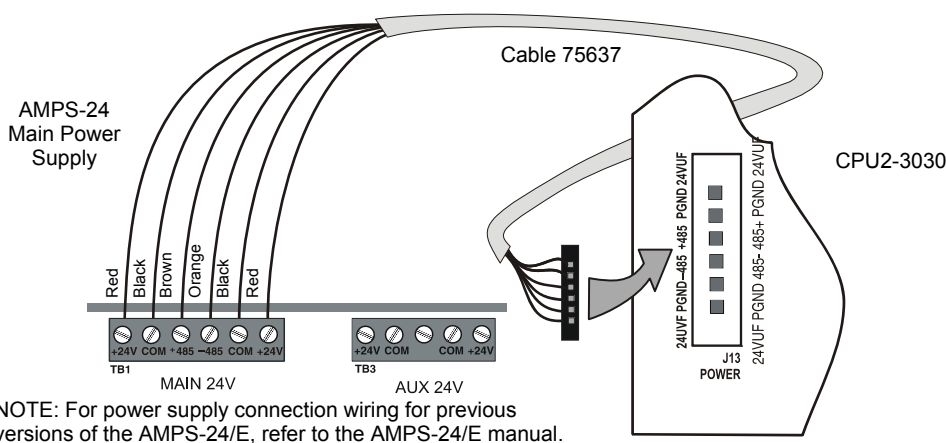

Figure 3.18 DC Power Connections: Main Power Supply

3.10.3 Checking AC Power

Table 3.2 contains a checklist for checking the system with AC power applied to the main power supply:



CAUTION:
WHILE CHECKING AC POWER, MAKE SURE BATTERIES ARE NOT CONNECTED.

Component	Status
CPU	The green Power indicator will come on when power is coming from the main power supply. The yellow Trouble indicator will come on until batteries are connected.
Main power supply	The green AC indicator will come on when AC is supplied. The yellow Trouble indicator will come on until batteries are connected.
Each auxiliary power supply	The yellow Trouble indicator comes on because batteries are not connected.

Table 3.2 AC Power Checklist

3.10.4 Auxiliary Power Supply Connections

If an optional auxiliary power supply is installed in the cabinet, connect it at this time. Follow the connection procedures specified in your auxiliary power supply manual.

3.11 UL Power-limited Wiring Requirements

Power-limited and non-power-limited circuit wiring must remain separated in the cabinet. All power-limited circuit wiring must remain at least 0.25 inches (6.35 mm) from any non-power-limited circuit wiring. All power-limited and non-power-limited circuit wiring must enter and exit the cabinet through different knockout and or conduits. To maintain separations easily, it is recommended that non-power-limited modules are grouped together. For example, use a separate row or designated side of the enclosure so that power-limited and non-power-limited wiring do not cross. Install tie wraps and adhesive squares to secure the wiring.

For a quick reference to control panel circuits, refer to Figure 2.1 at the start of this manual. The power-limiting label inside your cabinet door identifies which compatible modules have power-limited or non-power-limited wiring.

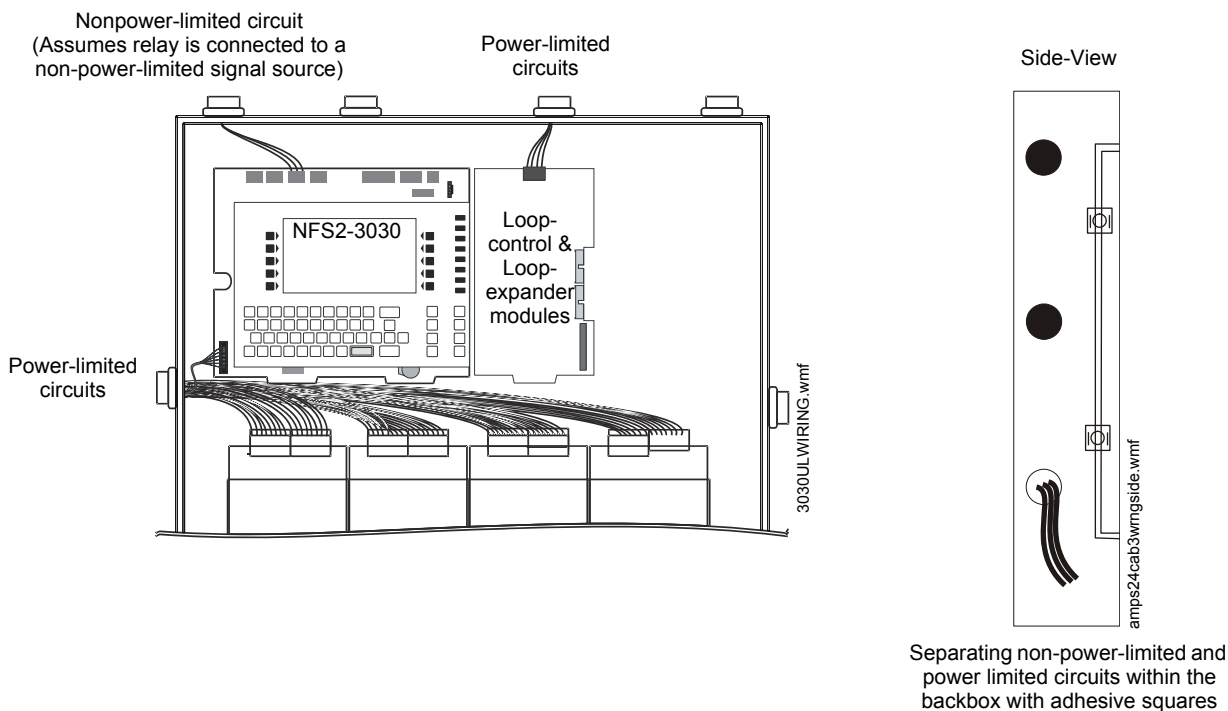

Figure 3.19 Typical Wiring in a Four-Row Backbox

Some devices (such as ACM-8R and LDM-R32) are power-limited only when connected to power-limited sources. When one of these devices is connected to a non-power-limited source, the power-limited marking must be removed, and at the time of installation, each non-power-limited circuit connected to these modules must be identified in the space provided on the cabinet door label.



NOTE: Relays are power-limited only when connected to power-limited sources for the relay outputs.

3.12 Central Station Fire Alarm System Canadian Requirements

For Canadian applications requiring a second dial-out option, refer to the following illustration for UDACT-2 and TM-4 setup:

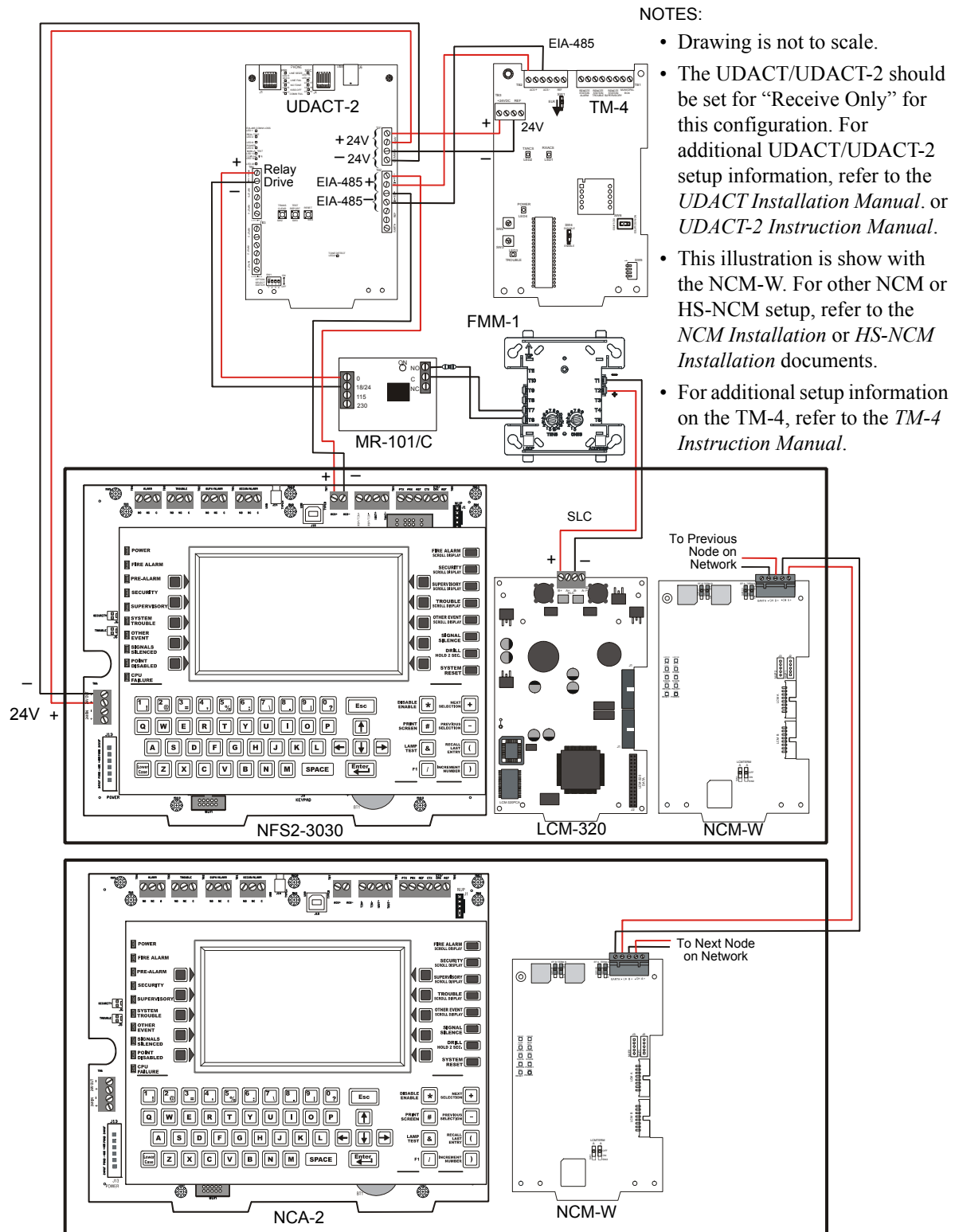

Figure 3.20 Central Station Canadian Requirements for Second Dial-Out Connection

3.13 ULC Remote Connection Feature

ULC requires that devices such as TM-4 and UDACT/UDACT-2 be disconnected during annual testing to prevent transmission of false alarms.

Disconnecting TM-4 for Annual Testing Follow standard installation procedures as described in the TM-4 installation documentation. To disable reporting, slide SW4 Disable All Output switch from “Enable” to “Disable.” Refer to TM-4 documentation for product drawing.

Disconnecting UDACT/UDACT-2 for Annual Testing Install UDACT/UDACT-2 as the last device on the EIA-485 line, with a listed key switch such as AKS-1B installed on the EIA-485 line. In this case only, install the ELR between the EIA-485 wires just in advance of the key switch (see Figure 3.21). The key switch should be installed so that key-removed is the closed position; it should be located inside the same backbox as the UDACT/UDACT-2, as close to the UDACT/UDACT-2 as possible.



NOTE: During testing when the key switch is turned, the panel will report a communication failure for the UDACT or UDACT-2's address.

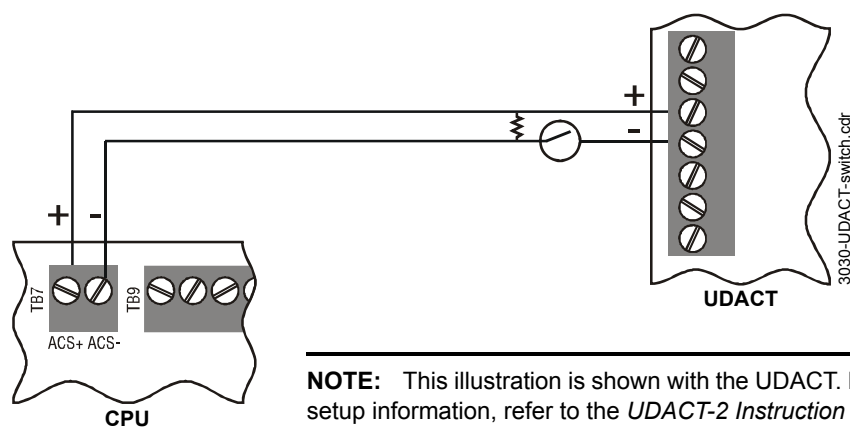

NOTE: This illustration is shown with the UDACT. For UDACT-2 setup information, refer to the *UDACT-2 Instruction Manual*.

Figure 3.21 Wiring a Key Switch to Disconnect UDACT During Annual Testing

3.14 Installing Printers

This section contains information on connecting a printer to the CPU and for setting the printer options. The basic steps are as follows:

1. Make custom cable & connect it from printer to EIA-232 terminal on the CPU.
2. Connect printer's power supply.
3. Configure printer settings as described in printer documentation.

■ Overview: PRN Printer

The PRN provides a printed record (80 columns on standard 9" x 11" tractor-feed paper) of all system events (alarm, trouble) and status changes within the system. The control panel can be configured to time-stamp the printout with the current time-of-day and date for each event. The printer can be located up to 50 feet (15.25 m) from the control panel. Installation and configuration instructions follow.

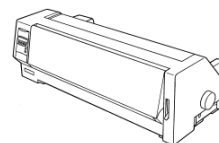

6769cov.tif

■ **Overview: Keltron Remote Printer (Model VS4095)**

The VS4095 is a two-color (red and black), 40-column, 24 VDC printer that can print up to 50 messages in 90 seconds. This printer connects to the EIA-232 TB5 on the CPU and to the +24V screw on TB3 of AMPS-24/E, and mounts in a separate cabinet next to the control panel. The VS4095 meets UL fire and security requirements for an ancillary device; it is not ULC-listed. For more information on the Keltron printer, contact the manufacturer (Keltron Corp., Waltham, MA). Installation and configuration instructions follow.

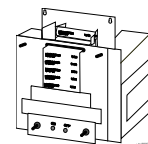

NOTE: Depending on which version of the AMPS-24/E is being used, the terminal block designations may differ from those listed. Please refer to the AMPS-24/E manual.

3.14.1 Printer Installation Sequence

1. Fabricate a custom cable to connect a printer to the system. Length of the cable will vary with each installation, but should not exceed a maximum length of 50 feet (15.24 meters). Printer must be installed in the same room as panel. Using overall foil/braided-shield twisted-pair cable, properly connect one end to the DB-25 Connector (provided) using the wiring specifications shown in Figure 3.22.
2. Tighten clamp on connector to secure cable. Connect the four open leads of the custom cable to the TB5 terminal block on the CPU as shown in Figure 3.22.

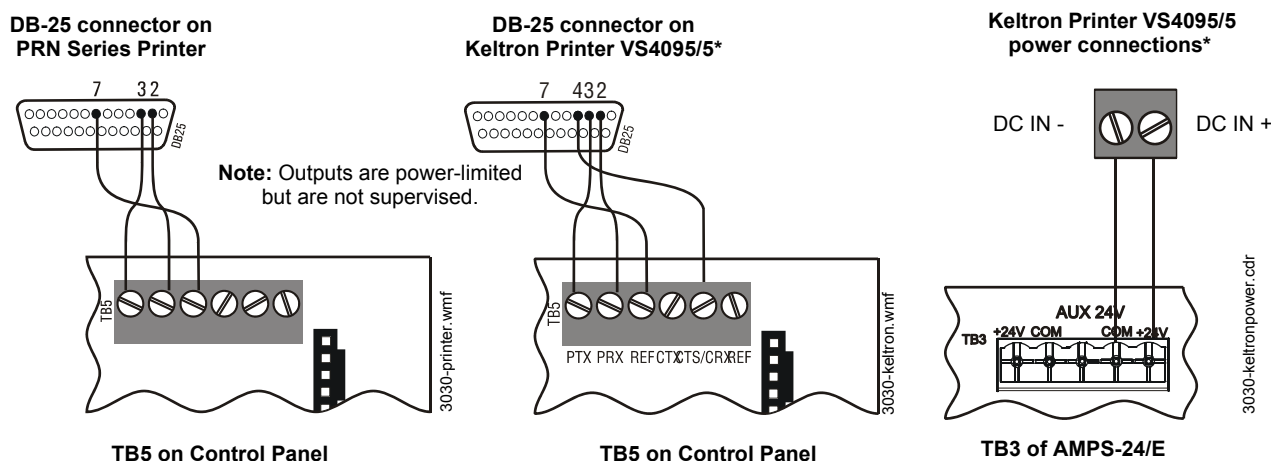

*Note: VS4095/5 is not ULC-listed.

Figure 3.22 Printer Connections

3. If installing a Keltron Printer VS4095/5, connect 24 VDC non-resettable power from a UL-listed power supply to the Keltron printer as shown in Figure 3.22 (14 AWG).
4. If installing a PRN series printer, plug it into your AC power source. **Note:** PRN printers require a 120 VAC, 50/60 Hz primary power source. If required for the fire alarm system configuration (for example, a Proprietary Fire Alarm System), a remote printer requires a secondary power source (battery backup). Because a secondary power source is not provided, use a separate Uninterruptable Power Supply (UPS) that is UL-listed for Fire Protective Signaling.
5. Plug the DB-25 connector end of the custom cable into the EIA-232 port of your printer. Tighten securely.
6. Configure the printer as described in Section 3.14.2 “Configuring the Printer”.



NOTE: Depending on which version of the AMPS-24/E is being used, the terminal block designations may differ from those listed. Please refer to the AMPS-24/E manual.

3.14.2 Configuring the Printer

Refer to the documentation supplied with your printer for instructions on configuring your printer.

PRN Printer Settings

Set the printer options (under the menu area) according to the settings listed in Table 3.3.

Option	Setting	Option	Setting
L/R Adjust	0	Menu Lock	ON
Font	HS Draft	Language	English
CPI	10 CPI	Paper	
LPI	6 LPI	Single	
Skip	0.0	Form Adjust	12/72
ESC Character	ESC	Trac 1	
Emulate	FX-850	Form Adjust	12/72
Bidirectional Copy	ON	Trac 2	
I/O		Form Adjust	12/72
Interface	Serial	Auto Sheet Feeder	
Buffer	40K	Form Adjust	12/72
Serial		Auto Tear	OFF
Baud	9600	F-Eject	OFF
Format	8 Bit, None, 1 Stop	Form Length	
Protocol *	ENQ/STX	Trac 1	
CG-TAB	Graphic	Lines	66
Character Set	Standard	Standard	10.5"
Country	E-USA ASCII	Trac 2	
Select Zero	ON	Lines	66
Auto-CR	OFF	Standard	10.5"
Auto-LF	OFF	Barcode	Off
		Barmode	Unsecured

*Protocol: When printing in graphics mode, set I/O Serial Protocol to "Robust XON/OFF".

Table 3.3 PRN Setup Options

Keltron Printer VS4095/5 Settings

The printer communicates using the following protocol:

- Baud Rate
 - Supervised mode: 2400
 - Unsupervised mode: 300
 (Supervision is a programmed setting; refer to the Panel Programming section of the Programming Manual for instructions.)
- Data bits: 8
- Parity: None
- Stop bits: 1

Set the printer DIP switches SP1 and SP2 according to settings in Table 3.4.

Supervised			Unsupervised			Supervised and Unsupervised		
SP1	On	Off	SP1	On	Off	SP2	On	Off
		X	1	X		1		X
	X		2		X	2		X
		X	3	X		3		X
		X	4		X	4		X
	X		5	X		5	X	
		X	6		X	6		X
	X		7	X		7	X	
	X		8	X		8	X	

Table 3.4 Keltron DIP Switch Settings

3.15 Wiring a Signaling Line Circuit (SLC)

3.15.1 SLC Overview

Communication between the CPU and intelligent and addressable initiating, monitor, and control devices takes place through a Signaling Line Circuit (SLC). You can wire an SLC to meet the requirements of NFPA Style 4, Style 6, or Style 7 circuits. This manual provides requirements and performance details specific to this control panel; for installation information and general information, refer to the *SLC Wiring Manual*.

For electrical specifications, see Appendix A.2 “SLC Loops”. For additional notes on SLC resistance values, see Section 5.3 “Operational Checks”.

3.15.2 SLC Capacity

The NFS2-3030 supports up to five pairs of loop control and expander modules, providing from one to ten SLC loops. Loop capacity depends on operating mode:

- Flash Scan: 01-159 intelligent detectors, 01-159 monitor and control modules
- CLIP: 0-99 intelligent detectors, 01-99 monitor and control modules

FlashScan devices can operate in either FlashScan or, for retrofit applications, in CLIP mode. Older models of CLIP devices only support addresses up to address 99. CLIP loops are limited to 99 detectors and 99 modules.



NOTE: Response times for CLIP loops may vary. CLIP loops must be tested to assure that actuation of notification appliances occurs within 10 seconds after activation of an initiating device. Systems with response time that exceed 10 seconds must be approved by the AHJ.

The following configuration guidelines may be used to improve the response times of CLIP loops:

1. All manual pull stations must be assigned addresses from 1-20.
2. Loops must be programmed for Rapid Poll (refer to the programming manual for specific instructions).
3. Modules on a fully loaded loop must adhere to a ratio of two monitor modules to one control module.

3.15.3 SLC Installation

Install loop control and expander modules as described in Section 3.8 “Connecting the Loop Control and Expander Modules”. Note that the unique SLC loop number assigned to a module does not need to match the module’s location in the cabinet. For details on designing, installing and configuring SLC loops, see the *SLC Wiring Manual*.

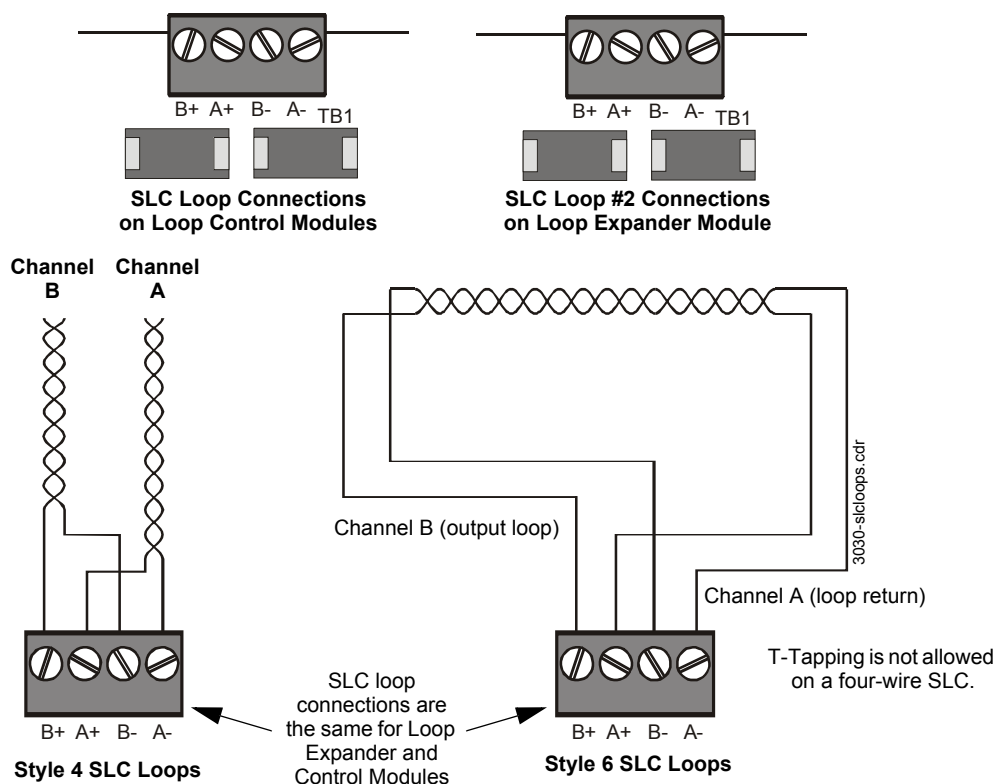

Figure 3.23 SLC Loop Connections and Wiring

3.16 Connecting a PC for Programming

A PC running the VeriFire® Tools programming utility can upload and download the operating program of the control panel when attached to J15 USB Connection, J1 Network/Service Connection (NUP) or to the second Network/Service connection on an attached wire or fiber version of the NCM or HS-NCM. Refer to the VeriFire® Tools CD for instructions.



NOTE: Download operations that change the basic program of the control panel must be performed by responsible service personnel in attendance at the control panel. After downloading a program, test the control panel in accordance with NFPA 72.

Section 4: Applications

4.1 Overview

A listing of chapters and topics covered in this section:

Chapter	Covers the following topics
Section 4.3 "NFPA 72 Central or Remote Station Fire Alarm System (Protected Premises Unit)"	How to install a UDACT/UDACT-2 with the CPU for use as a NFPA Central or Remote Station Fire Alarm System (Protected Premises Unit)
Section 4.4 "NFPA 72 Proprietary Fire Alarm Systems"	How to set up a Protected Premises Unit to communicate with a listed compatible Protected Premises Receiving Unit.
Section 4.5 "Fire/Security Applications"	How to use the CPU as a combination Fire/Security system, including the following: <ul style="list-style-type: none"> • Installing a Security Tamper Switch into the cabinet • Circuit Wiring



NOTE: NFS2-3030 is not listed for Canadian security application.

■ Municipal Box (Auxiliary)

Municipal Box applications require a TM-4 Transmitter module. Refer to the *Transmitter Module TM-4* installation document for installation details.

4.2 Devices Requiring External Power Supervision

With LCM-320 revision 2.0 and higher, certain type codes have external power supervision (FlashScan only) built into the software. An external power-supervision relay is required (see Figure 4.1) unless one of the following typecodes is selected for the device:

- Control
- Strobe
- Horn
- (Blank)
- Release Ckt
- Rel Ckt Ulc
- Nonreset Ctl
- Alarms Pend
- Gen Alarm
- Gen Super
- Gen Trouble
- Gen Pend
- Trouble Pend

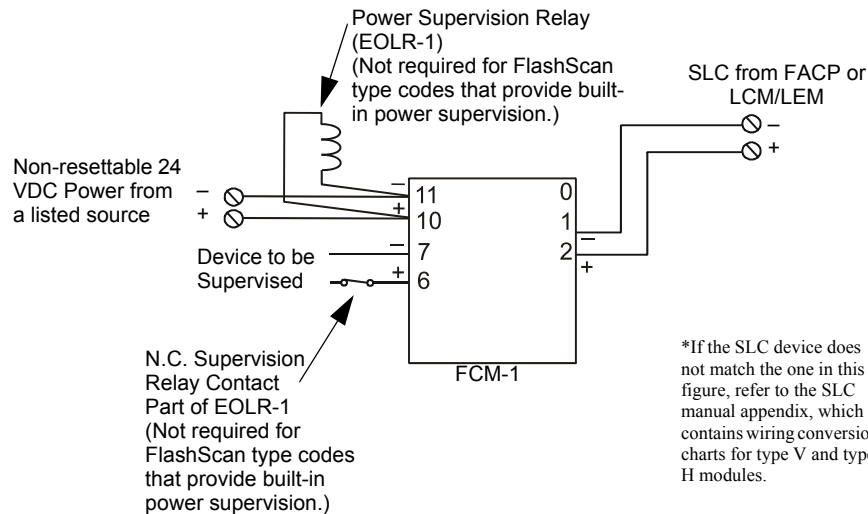

Figure 4.1 Enabling External Power Supervision Using Relays

3030-external-power-supth.H.wmf

4.3 NFPA 72 Central or Remote Station Fire Alarm System (Protected Premises Unit)

The figure below shows typical wiring diagram for a NFPA 72 Central Station Fire Alarm System (Protected Premises Unit) or a Remote Station Fire Alarm System (Protected Premises Unit) using the Universal Digital Alarm Communicator/Transmitter (UDACT) and NFS2-3030. Connect and program the UDACT according to the directions given in *The UDACT Instruction Manual*.



NOTE: An NFPA 72 Central Station requires 24 hours of standby power; an NFPA 72 Remote Station requires 60 hours of standby power.

Typical wiring of a UDACT with NFS2-3030:

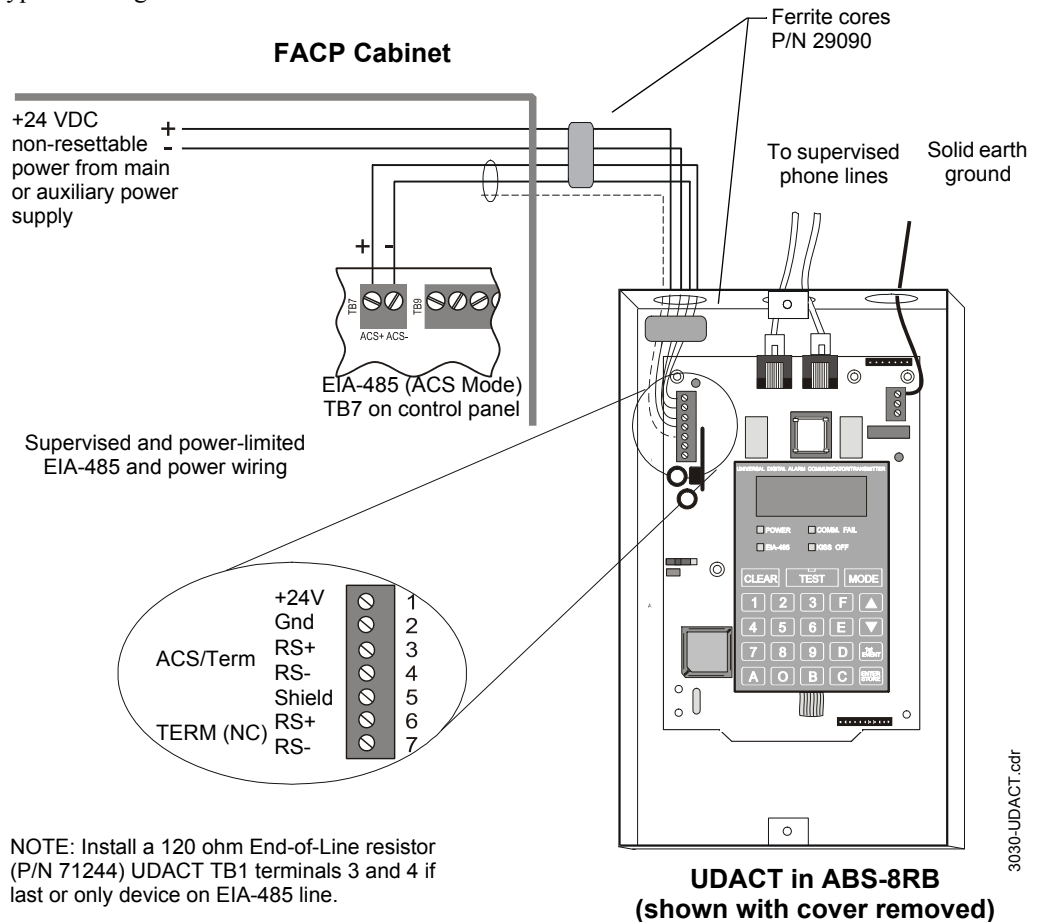

NOTE: Install a 120 ohm End-of-Line resistor (P/N 71244) UDACT TB1 terminals 3 and 4 if last or only device on EIA-485 line.

Figure 4.2 Typical Wiring Diagram for a Central Station Fire Alarm System



NOTE: This application can also be done with the TM-4 Transmitter; refer to the TM-4 Transmitter Module manual for more details.



NOTE: The following models do not comply with requirements for AC loss delay reporting when used with Central Station Protected Premises systems: AA-30, AA-120, AA-100, APS-6R, CHG-120.



NOTE: For additional setup information for UDACT-2, refer to the *UDACT-2 Installation Manual*.

4.4 NFPA 72 Proprietary Fire Alarm Systems

When connected and configured as a protected premises unit with monitor and relay modules, the NFS2-3030 will automatically transmit General Alarm, General Trouble, General Supervisory, and Security signals to a listed compatible Protected Premises Receiving Unit. A simplified drawing of connections between the receiving unit and the NFS2-3030 protected premises unit is shown in Figures 4.3 and 4.4.

Connect the receiving unit to the protected premises unit as shown in Section 4.3 “NFPA 72 Central or Remote Station Fire Alarm System (Protected Premises Unit)”.

Install and program the Receiving unit with type codes and zone mappings shown in Figure 4.3; see the programming manual for procedures.

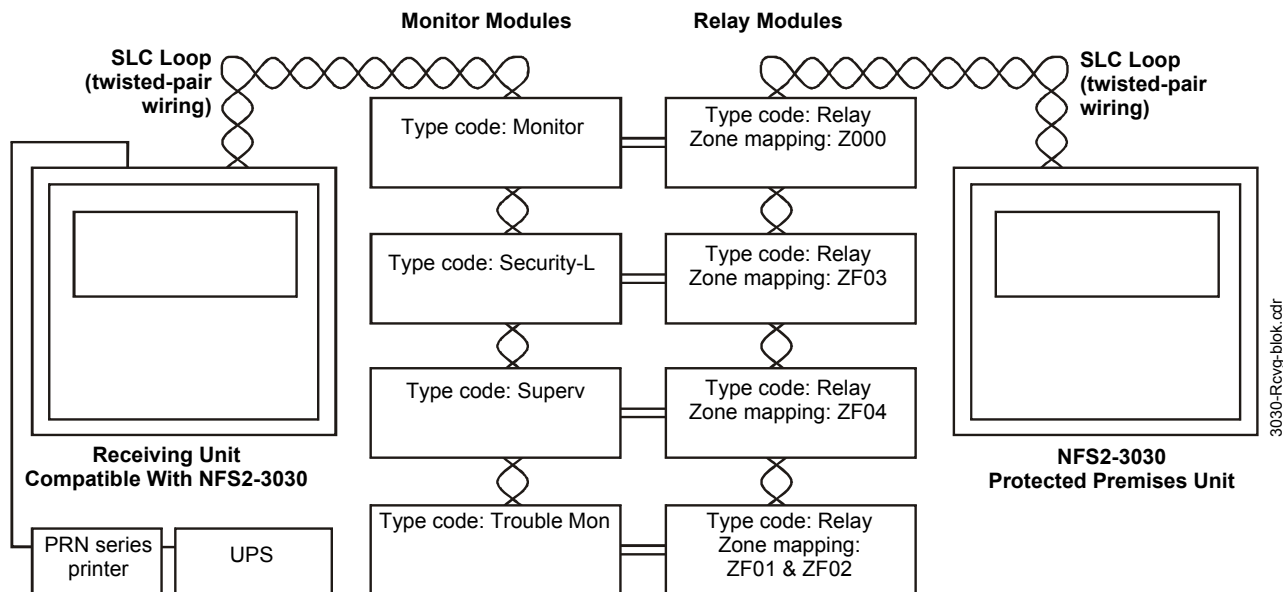

Note: Remote printers require 120 VAC, 50/60Hz primary power. A secondary power source (battery backup) is not provided; the use of a separate Uninterruptable Power Supply (UPS) 50 watt minimum, UL-listed for Fire Protective Signaling is recommended. A UPS is required for NFPA 72 Proprietary Protected Premises Receiving Unit Applications.

Figure 4.3 Typical Proprietary Fire Alarm Systems Wiring Connections: Block View

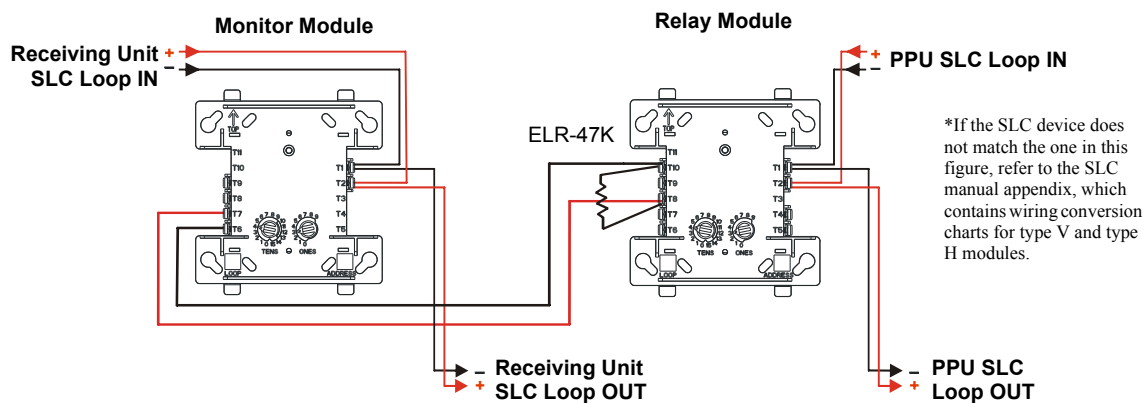

Figure 4.4 Typical Proprietary Fire Alarm Systems Wiring Connections: Detail View

4.5 Fire/Security Applications



NOTE: The NFS2-3030 is not approved for use in security applications in Canada.

4.5.1 General Operation

The NFS2-3030 can be used as a combination Fire/Security system when installed and operated according to the instructions in this section.

For security applications, program one or more monitor module (listed for security applications) with the SECURITY-L, SYSTEM MONITOR, or AREA MONITOR Type Codes, and wire as shown in Figure 4.6. Activating these types of modules lights the SECURITY LED, and displays a security alarm condition on the primary display. The panel sounder will sound until you acknowledge the Security alarm. You can also program additional sounders or output devices to activate with the security alarm initiating device. These type codes are designed to indicate an alarm in one or more of the following situations:

- (a) on an open or short circuit
- (b) on a $\pm 50\%$ change in resistance value from the End-of-Line resistor value
- (c) on loss of communication with the device.

A tamper switch installed in the cabinet door will indicate a door tamper condition whenever the door is open. If the control panel indicates a Security alarm, you can perform acknowledge, signal silence, and system reset from the control panel.

Damage can result from incorrect wiring connections.

4.5.2 General Security Requirements

The following security requirements must be met:

- Use AMPS-24/E power supply.
- Shielded cable must be used on all input/output wiring associated with security functions.
- SLC Loop Shielding (refer to the *SLC Wiring Manual*).
- Security Module I/O Circuit Shielding - terminate the shield at earth ground at the junction box containing the module.
- When employed as a Protected Premises Unit, the NFS2-3030 cabinet door must be wired with an STS-1 Tamper Switch that is monitored by the control panel.

- If the system has arming and disarming capability, a ringback signal from the Central Station to the arming location is required. The ringback signal informs the Protected Premises Control Panel that the signal to arm/disarm has been received by the Central Station.
- A single SLC loop may be used for both Fire and Security Device Connections.

There are five software type IDs associated with security operation: ACCESS MONITOR alarm, AREA MONITOR, EQUIP MONITOR, SECURITY-L, and SYS MONITOR. There is also one software function, Security Delay (SDEL). These software elements are essential to all aspects of security operation, including Control-By-Event (CBE) programming. Devices with the type IDs ACCESS MONITOR and EQUIP MONITOR do not automatically display at the LCD or require state change acknowledgment. State changes in devices with these software types may be output at a printer. Refer to this panel's Programming manual for more information about the characteristics of software type IDs.



WARNING:

XP TRANSPONDER CIRCUITS (XPP-1, XPM-8, XPC-8, XPR-8, XPM-8L) ARE NOT SUITABLE FOR SECURITY APPLICATIONS.

4.5.3 Installing a Security Tamper Switch

Follow the instructions below to wire the cabinet with a Security Tamper Switch kit model STS-1.

1. Install the STS-1 Tamper Switch onto the side of the backbox opposite the door hinge, pushing the switch through the opening until it snaps into place.
2. Install the magnet on the same side of the cabinet door as the lock. Push the magnet through the opening in the door until it snaps into place.
3. Connect the STS-1 connector to J6 Security on the CPU.
4. Program panel supervision for Tamper Input "Yes".

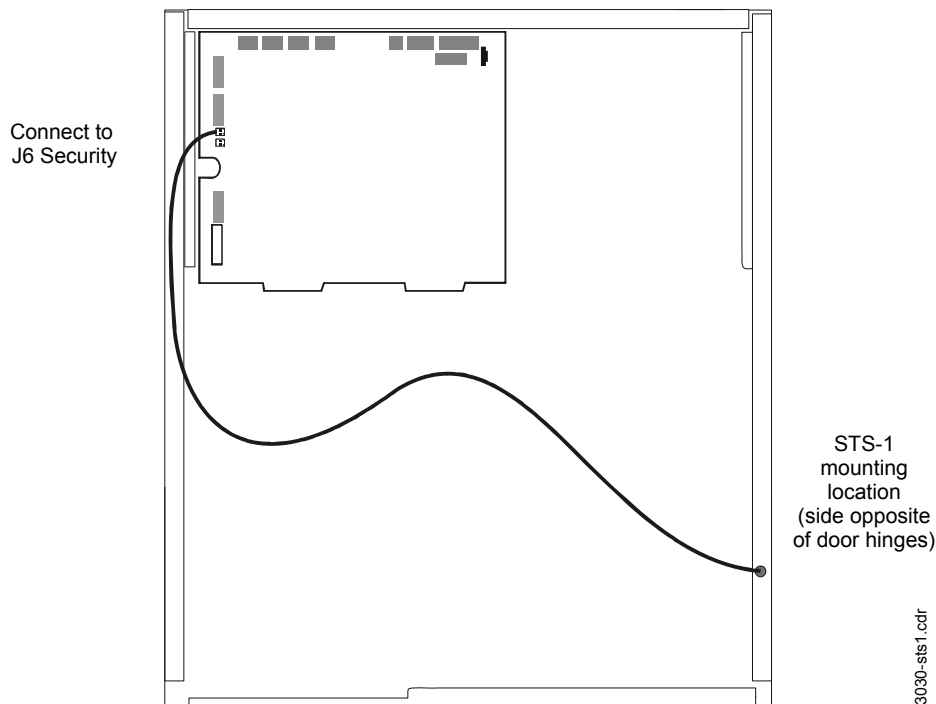

Figure 4.5 Installing the STS-1 Security Tamper Switch

4.5.4 Receiving Unit

For applications requiring transmission of security alarm information to a central receiving unit, the CPU may be connected to a compatible receiving unit. For information on configuring the Receiving unit for Combination Fire/Security applications, refer to the documentation for that control panel.

4.5.5 Programming

The control panel can communicate with any number of security devices. To do so, program the points as follows:

1. Select the address of the module(s) to be used for security.
2. Select one of the type codes described in Section 4.5.2 “General Security Requirements”.

For detailed instruction on programming Type Codes, refer to the *Programming Manual*.

4.5.6 Wiring for Proprietary Security Alarm Applications

Typical wiring for proprietary security alarm applications with the FMM-1 module.

Note the following:

- The module is programmed with one of five type codes (see Section 4.5.2 “General Security Requirements”).
- Supplementary use only applies to UL-listed systems.
- NAC devices used for security cannot be shared with fire NAC devices.
- Refer to the *Device Compatibility Document* for compatible NAC devices.
- All monitor modules used for security application must be installed in the control panel cabinet with STS-1 Security Tamper Switch.

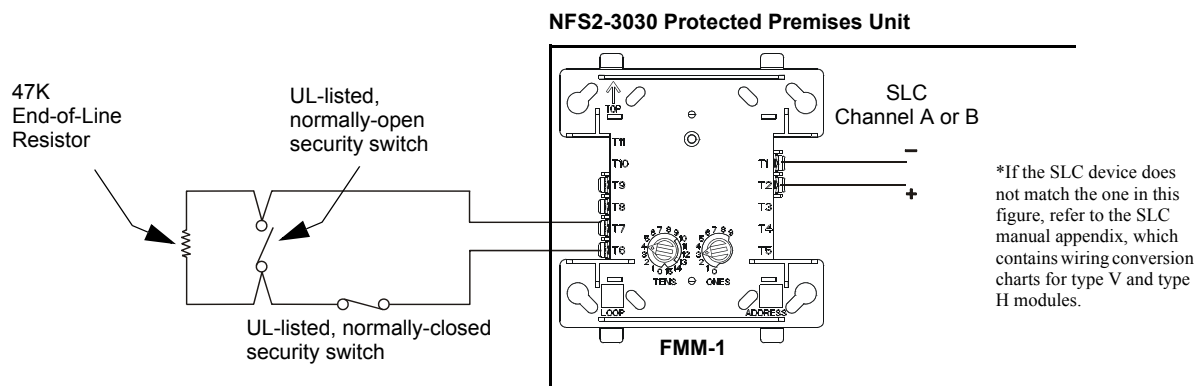
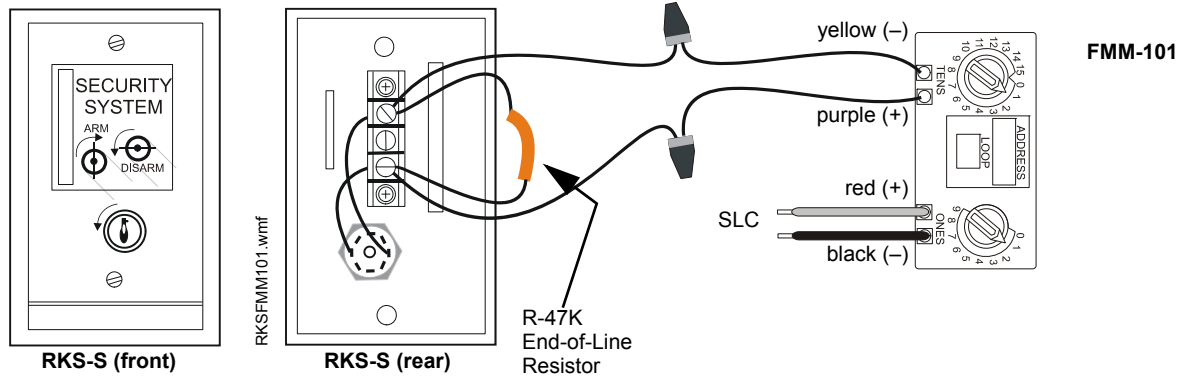

Figure 4.6 Wiring Diagram for Proprietary Security Alarm Applications

4.5.7 Connecting an RKS-S Remote Key Switch

The RKS-S Remote Key Switch arms and disarms the system. It can be mounted in a UL listed single-gang electrical box. Both the monitor module and RKS-S must be mounted within the protected area. Figure 4.7 and Figure 4.8, respectively, depict the connection of the FMM-101 or FMM-1 module to the RKS-S.



WARNING:
XP TRANSPONDER CIRCUITS (XPP-1, XPM-8, XPC-8, XPR-8, XPM-8L) ARE NOT SUITABLE FOR SECURITY APPLICATIONS.

Figure 4.7 Connecting the FMM-101 Module to the RKS-S

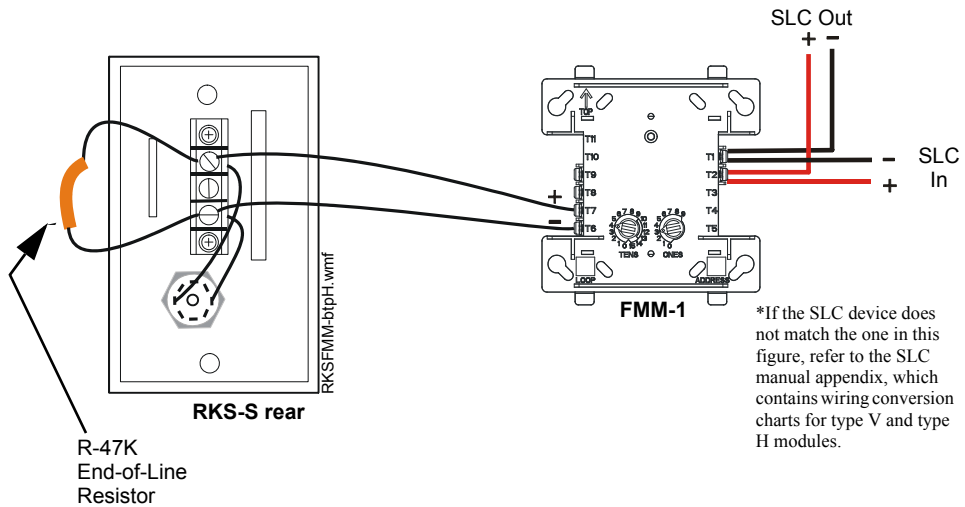

*If the SLC device does not match the one in this figure, refer to the SLC manual appendix, which contains wiring conversion charts for type V and type H modules.

Figure 4.8 Connecting the FMM-1 Module to the RKS-S

4.5.8 Single Tenant Security System with Entry/Exit Delay

The following system requirements are illustrated in Figure 4.9.

- One NFS2-3030 Control Panel
- Multiple Security Supervisory Circuits Reporting to Central Station as a Single Area
- The minimum security equipment required is as follows:
 - Multiple MM Monitor Modules per Protected Area
 - One Group Interface for security alarm
 - One Group Interface to generate trouble arming system
 - Contact Switch for Each Entry/Exit Door
 - RKS-S Key Switch
 - MM Monitor Modules
 - Remote Annunciator for Each Entry/Exit Door (ACM-24AT, ACM-48A, ACM-16AT, ACM-32A)
 - Security Devices

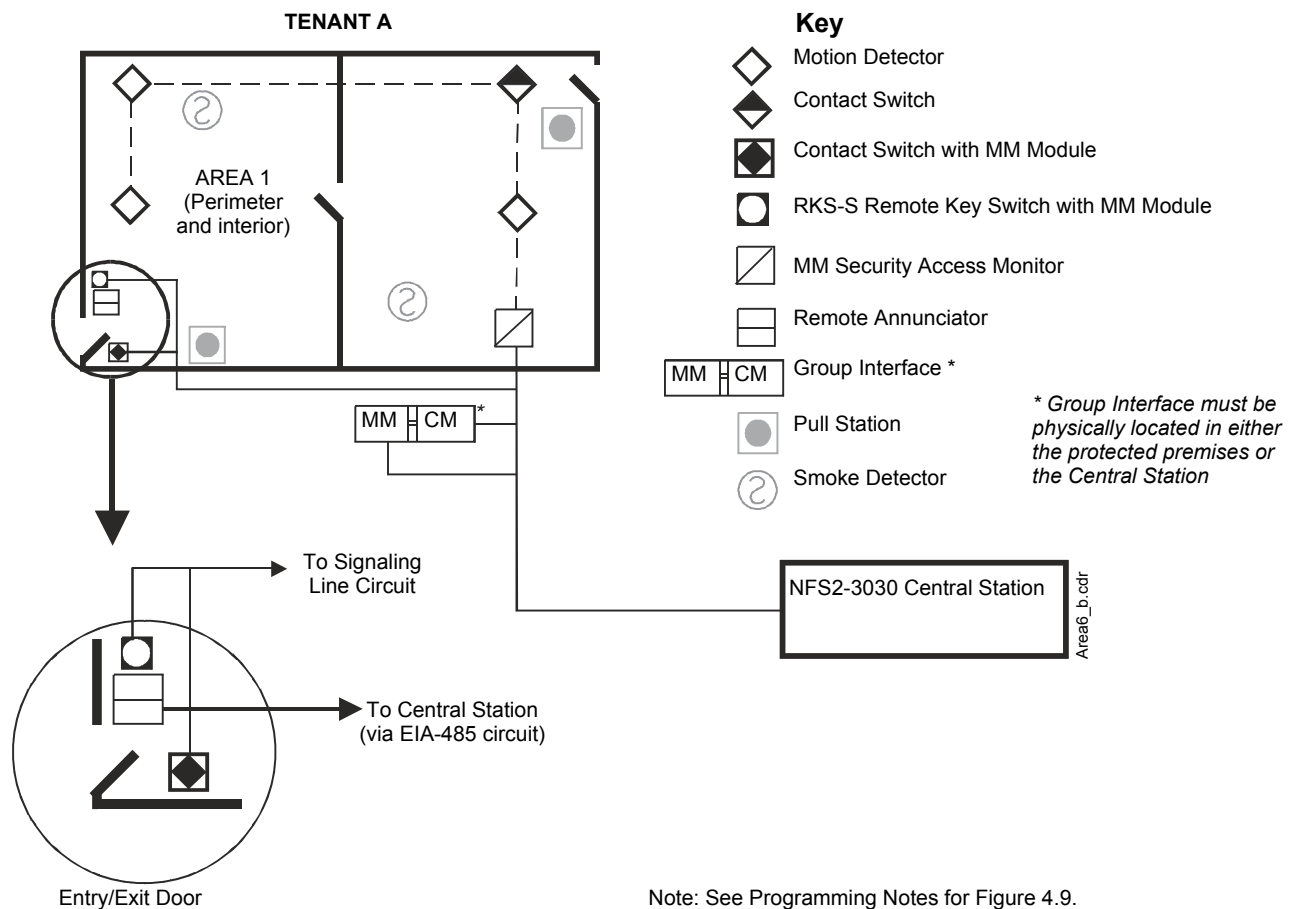

Figure 4.9 Single Tenant Security System with Entry/Exit Delay

Programming Notes for Figure 4.9

1. Programming of Key Switch, Access Points, and Motion Detection

- RKS Remote Key Switch with Monitor Module**
 Address: LXXMYYY (arbitrary)
 Type ID: ACCESS MONITOR
 Zone Map: (none)
 Custom Label: Arming Switch

Contact Switches with Monitor Modules

Address: LXXMYYY (arbitrary)
 Type ID: ACCESS MONITOR
 Zone Map: ZA
 Custom Label: Exit Door #

Motion Detectors with Monitor Modules

Address: LXXMYYY (arbitrary)
 Type ID: ACCESS MONITOR
 Zone Map: ZB
 Custom Label: Motion Detection

2. Programming of Logic Equations

Logic Equation for 1 minute exit delay:

$$ZLa^* = DEL(01:00, 00:00, \text{address of key switch})$$

Logic Equation for Trouble arming system:

$$ZLb^* = AND(ZA, \text{address of key switch}, NOT(ZLa))$$

Logic Equation to arm system:

$$ZLc^* = AND(ZLa, NOT(ZLb))$$

Logic Equation providing 30-second entry delay:

$$ZLd^* = SDEL(00:30, 00:30, ZA)$$

Logic Equation for Security Alarm:

$$ZLe^* = AND(ZLc, OR(ZLd))$$

*Follow the following restrictions on values:

$$a < b < c < d < e$$

3. Programming Group Interfaces

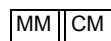

Group Interface for Trouble when system is armed while access point(s) active

A. CM programming

Address: LXXMYYY (arbitrary)
 Type ID: RELAY
 Zone Map: ZLb
 Custom Label: Arming Trouble Group Output
 Signal Silence: No
 Walk Test: Yes/No (Installer Specified)
 Switch Inhibit: Yes

B. MM Programming

Address: LXXMYYY (arbitrary)
 Type ID: TROUBLE MON
 Zone Map: (none)

Group Interface for Security Alarm

A. CM programming

Address: LXXMYYY (arbitrary)
 Type ID: RELAY
 Zone Map: ZLe
 Custom Label: Security Group Output
 Signal Silence: No
 Walk Test: Yes/No (Installer Specified)
 Switch Inhibit: Yes

B. MM Programming

Address: LXXMYYY (arbitrary)
 Type ID: SECURITY-L
 Zone Map: (none)

4.5.9 Security Annunciation

A1P1
 Mode: Monitor
 Source: ZLc

A1P2
 Mode: Monitor
 Source: ZLe

A1P3
 Mode: Monitor
 Source: LXXMY

A1P4
 Mode: Monitor
 Source: LXXMY

Additional doors can be monitored, up to the number of available annunciator points.

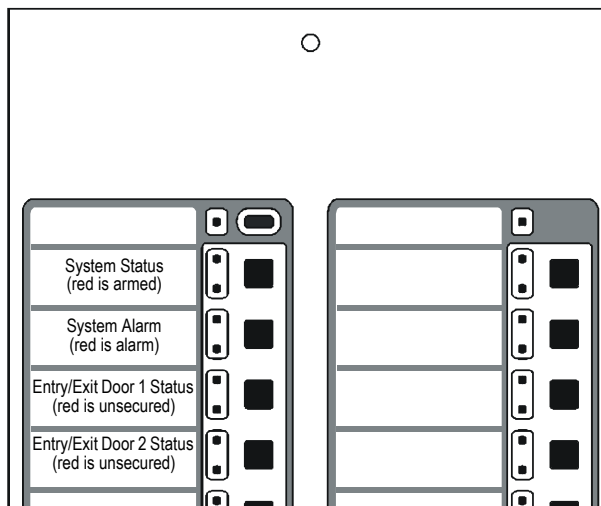

Figure 4.10 Sample Annunciator Display

acm-24atface.cdr

4.6 Releasing Applications

4.6.1 Overview

This control panel can be used for non-hazardous agent release or preaction/deluge control applications via the SLC loop. In a properly configured system with compatible, listed actuating and initiating devices, this control panel complies with the following NFPA standards for installation in accordance with the acceptable standard:

Standard	Covers
NFPA 13	Sprinkler Systems
NFPA 15	Water Spray Systems
NFPA 16	Foam-Water Deluge and Foam-water Spray Systems
NFPA 17	Dry Chemical Extinguishing Systems
NFPA 17A	Wet Chemical Extinguishing Systems
NFPA 2001	Clean Agent Fire Extinguishing Systems

Table 4.1 NFPA Standards for Releasing Applications

Refer to installation documents for the individual SLC loop device for voltage and maximum current requirements.

4.6.2 Programming

The control panel supports up to ten releasing software zones. You can map these zones to activate control modules. Program control module FCM-1 or FCM-1-REL for the appropriate Type Code according to the chart below:

Type Code: RELEASE CKT <ul style="list-style-type: none"> For use in UL applications Do not use REL-47K Cannot use power-limited wiring Supervised for open circuit only Supervised for power loss 	Type Code: REL CKT ULC <ul style="list-style-type: none"> For use in UL or ULC applications Requires REL-47K at solenoid Power-limited wiring Supervised for open circuit and shorts Supervised for power loss
--	--

For more information, refer to the *NFS2-3030 Programming Manual*.

4.6.3 Wiring

Make sure to keep total system current within the limits of the power supply. You can power the module from the power supply of the control panel or any UL-listed 24 VDC regulated power-limited power supply for Fire Protective Signaling. For more information, refer to the *Device Compatibility Document*.

References to wiring diagrams for releasing applications:

- To connect a releasing device to control module FCM-1, refer to Section 4.7.
- To connect an NBG-12LRA Agent Release-Abort Station, refer to Section 4.9.

4.7 Connecting a Releasing Device to FCM-1 Control Modules (Retrofit applications only)

Typical Connections Figure 4.11 shows typical connections for wiring a releasing device to this module. For ULC applications, REL-47K is required; see chart in Circuit Requirements below.

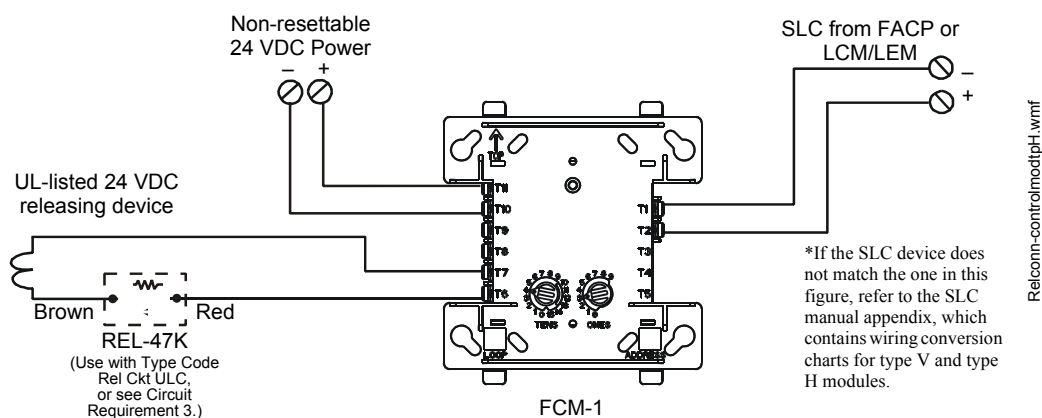

Note: See Circuit Requirements below.

Devices for use in releasing applications **must** be programmed as type code RELEASE CIRCUIT or REL CKT ULC.

Figure 4.11 Typical Connection of a 24 VDC Releasing Device to the FCM-1 Control Module

Circuit Requirements When connecting releasing devices to FCM-1 control modules, note the following:

1. For NFPA 13 and 15 applications, disable the Soak Timer (Soak=0000); for NFPA 16 applications, set the Soak Timer (0600-0900 seconds). Refer to the *NFS2-3030 Programming Manual* for instructions on setting the Soak Timer.
2. For applications using power-limited circuits:
 - a) Use an End-of-Line device (P/N REL-47K) with FCM-1 modules. Connect the an End-of-Line device as shown in Figure 4.11.
 - b) All wiring for releasing circuits is supervised against open and shorts.
 - c) Program the releasing circuit for Type Code REL CKT ULC.
3. For applications not requiring power-limited circuits:
 - a) End-of-Line devices (P/N REL-47K) are not required; however, the releasing device circuit is not supervised against shorts.
 - b) Limited energy cable cannot be used for wiring of a releasing device circuit.
 - c) Maintain a 0.25 inch (6.35 mm) spacing between the releasing circuit device wiring and any power-limited circuit wiring.
 - d) In non-power-limited applications, program the releasing circuit for Type Code RELEASE CKT.



NOTE: As per UL 864 9th edition, a supervisory signal must be indicated at the panel whenever a releasing circuit is physically disconnected. Use a monitor module to monitor dry contacts off the switch. See figure 4.12. Refer to the SLC Manual for detailed wiring information.

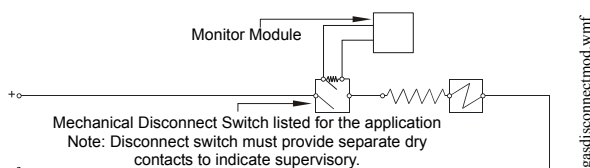

Figure 4.12 Typical Connection of a Mechanical Disconnect Switch

4.8 Connecting Releasing Devices to FCM-1-REL Control Modules

Typical Connections Figure 4.11 shows typical connections for wiring a releasing device to the FCM-1-REL. Refer to the Device Compatibility Document for a compatible releasing devices.

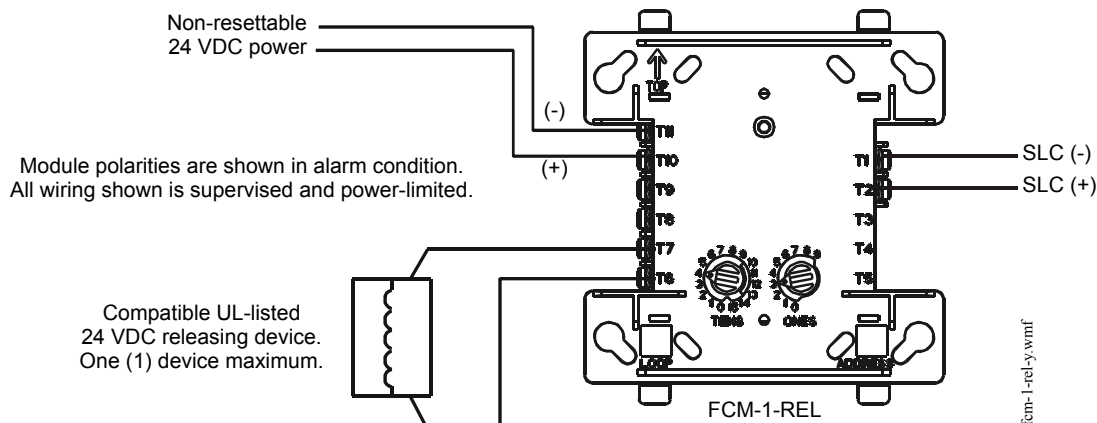

Figure 4.13 NPFA Style Y (Class B) Wiring of the FCM-1-REL

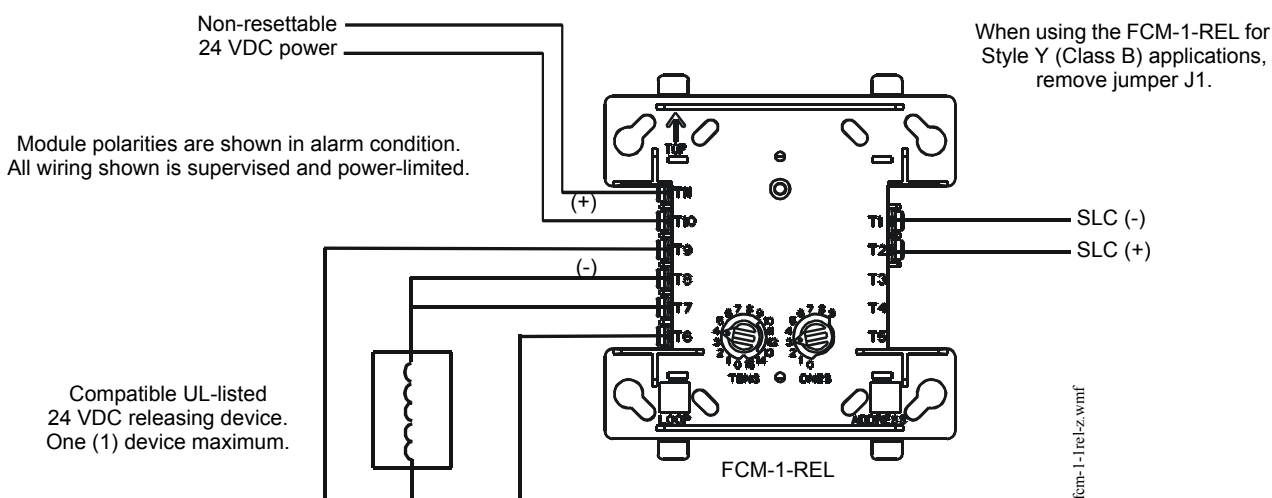

Figure 4.13 NPFA Style Z (Class A) Wiring of the FCM-1-REL

NOTE: With software version 14.0 or higher ALL new FlashScan Mode SLC releasing applications require the FCM-1-REL control module. The V-type FCM-1 control module may be used in SLC releasing applications with software version 14.0 or higher. H-type FCM-1 control modules do not support FlashScan mode releasing applications with software version 14.0 or higher. Use H-type FCM-1 for CLIP mode SLC releasing applications.

Critical Requirements. When connecting a releasing device to the FCM-1-REL module, note the following:

1. See “Power Considerations” on page 52 for information on monitoring 24 VDC power.
2. Do not T-tap or branch a Style Y or Style Z circuit.
3. Only one (1) 24V solenoid or two (2) 12V solenoids in series can be connected to the FCM-1-REL.
4. Do not loop wiring under the screw terminals. Break the wire run to provide supervision of connections.
5. All applications using the FCM-1-REL are power-limited:
 - a. Program the releasing circuit for Type Code REL CKT ULC or RELEASE CKT.
 - b. Circuits are supervised against opens and shorts.
6. Refer to the *NFS2-3030 Programming Manual* for instructions on setting the Soak Timer.

The FCM-1-REL module must be programmed with the correct releasing type code listed in the *NFS2-3030 Programming Manual*.

4.9 Connecting an NBG-12LRA Agent Release-Abort Station

Typical Connections Figure 4.14 shows typical connections for wiring an NBG-12LRA Agent Release-Abort Station.

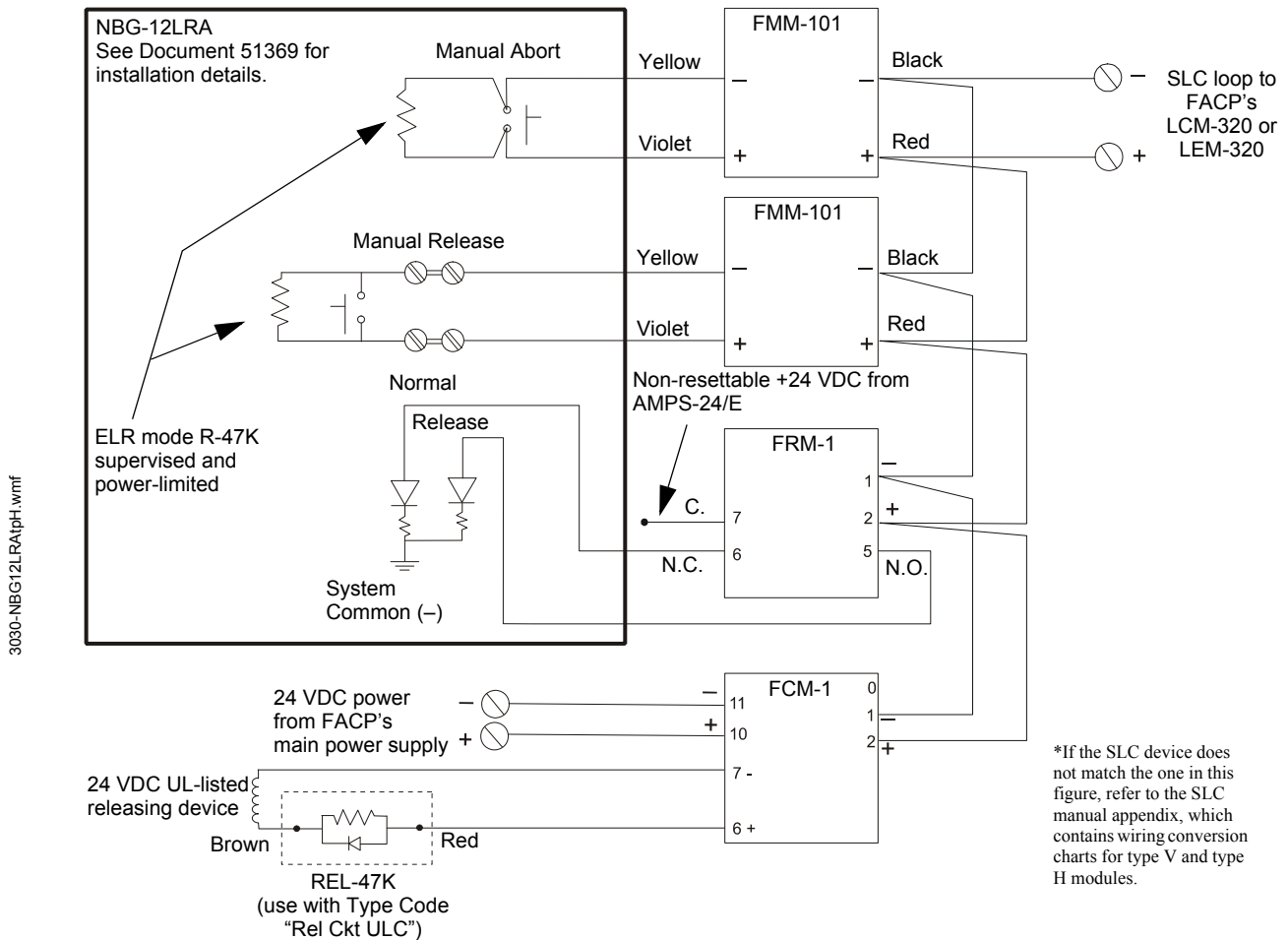

Figure 4.14 Typical Connections for an NBG-12LRA Agent Release-Abort Station



NOTE: See Circuit Requirements for Section 4.7, "Connecting a Releasing Device to FCM-1 Control Modules (Retrofit applications only)", on page 54.



NOTE: Devices for use in releasing applications must be programmed as type code RELEASE CIRCUIT or REL CKT ULC.

Section 5: Testing the System

5.1 Acceptance Test

When finished with the original installation and all modifications, conduct a complete operational test on the entire installation to verify compliance with applicable NFPA standards. Testing should be conducted by a factory-trained fire alarm technician in the presence of a representative of the Authority Having Jurisdiction and the owner's representative. Follow procedures outlined in NFPA Standard 72's section *Inspection, Testing and Maintenance*.

5.2 Periodic Testing and Service

Periodic testing and servicing of the control panel, all initiating and notification devices, and any other associated equipment is essential to ensure proper and reliable operation. Test and service the control panel according to the schedules and procedures outlined in the following documents:

- NFPA Standard 72, *Inspection, Testing and Maintenance*.
- Service manuals and instructions for the peripheral devices installed in your system. Correct any trouble condition or malfunction immediately.

5.3 Operational Checks

Between formal periodic testing and servicing intervals, the following operation checks should be performed monthly, or more frequently when required by the Authority Having Jurisdiction.

- Disconnect all releasing devices to prevent accidental activation.



WARNING: RELEASING DEVICES SHOULD BE PHYSICALLY DISCONNECTED. DO NOT USE SOFTWARE DISABLE FUNCTIONS IN THE PANEL AS LOCKOUT.

- Check that the green POWER LED lights.
- Check that all status LEDs are off.
- Press and hold the LAMP TEST key. Verify that all LEDs and all LCD display segments work.
- Before proceeding: a) notify the fire department and the central alarm receiving station if transmitting alarm conditions; b) notify facility personnel of the test so that alarm sounding devices are disregarded during the test period; and c) when necessary, disable activation of alarm notification appliances and speakers to prevent their sounding.
- Activate an Initiating Device Circuit using an alarm initiating device or an addressable initiating device on the SLC and check that all programmed active notification appliances function. Reset the alarm initiating device, the control panel, and any other associated equipment. In voice alarm applications, confirm that the proper tone(s) and/or messages sound during alarm conditions. Select the paging function and confirm that the message can be heard in the affected fire zones. Repeat the above step with each Initiating Device Circuit and each addressable device.



NOTE: SLC Resistance Values:

The total DC resistance of the SLC pair cannot exceed 50 ohms.

For instructions on how to measure the total DC resistance of a populated SLC pair, refer to the "Measuring Loop Resistance" section of the *SLC Wiring Manual* (P/N 51253).

The minimum DC resistance between conductors of an unpopulated SLC pair cannot be less than 1 K ohms.

Measure DC resistance on an unpopulated loop as shown in Figure 5.1 on page 59.

continued...

- ❑ Zero Ohms to ground will cause a ground fault.
- ❑ On systems equipped with a firefighter's telephone circuit, make a call from a telephone circuit and confirm a ring indication. Answer the call and confirm communication with the incoming caller. End the call and repeat for each telephone circuit in the system.
- ❑ Remove AC power, activate an Initiating Device Circuit through an alarm initiating device or an addressable initiating device on the SLC, and check that programmed active notification appliances sound, and alarm indicators illuminate. Measure the battery voltage with notification appliances active. Replace any battery with a terminal voltage less than 21.6 VDC and reapply AC Power.



NOTE: The battery test requires fully charged batteries. If batteries are new or discharged due to a recent power outage, allow the batteries to charge for 48 hours before testing.

- ❑ Return all circuits to their pretest condition.
- ❑ Check that all status LEDs are off and the green POWER LED is on.
- ❑ Notify fire, central station and/or building personnel when you finish testing the system.

Step 1. Disconnect the SLC channel B (Out) and SLC channel A (Return) at the control panel.

Step 2. Measure and record the resistance at SLC Out.

Step 3. Measure and record the resistance at SLC Return.

The minimum resistance is the lesser of two and three.

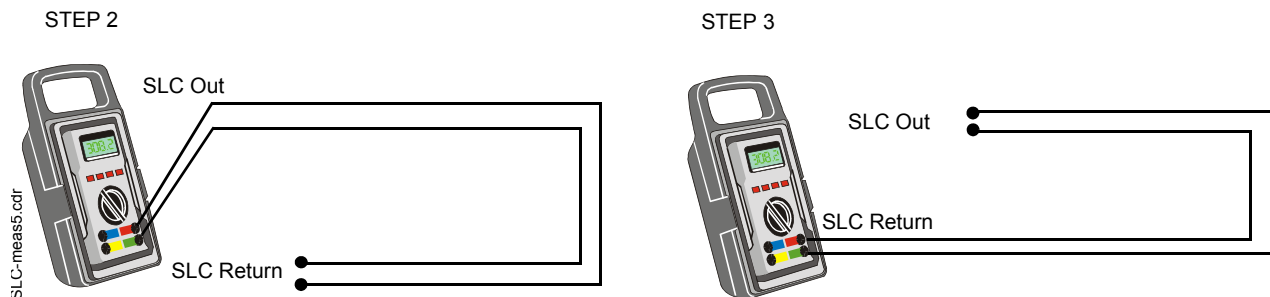

Figure 5.1 Measuring DC Resistance on an Unpopulated SLC Loop

5.4 Battery Checks and Maintenance

Maintenance-free sealed lead-acid batteries used in the system do not require the addition of water or electrolyte. These batteries are charged and maintained in a fully charged state by the main power supply's float charger during normal system operation. A discharged battery typically reaches the float voltage of 27.6 VDC within 48 hours.

Follow the local AHJ and manufacturer recommendations for battery replacement intervals. Minimal replacement battery capacity appears on the control panel marking label. Immediately replace a leaking or damaged battery. You can get replacement batteries from the manufacturer.



WARNING: BATTERIES CONTAIN SULFURIC ACID, WHICH CAN CAUSE SEVERE BURNS TO THE SKIN AND EYES AND DAMAGE TO FABRICS.

- If a battery leaks and contact is made with the Sulfuric Acid, immediately flush skin and/or eyes with water for at least 15 minutes. Water and household baking soda provides a good neutralizing solution for Sulfuric Acid.
- If Sulfuric Acid gets into eyes, seek immediate medical attention.
- Ensure proper handling of the battery to prevent short circuits.

Take care to avoid accidental shorting of the leads from uninsulated work benches, tools, bracelets, rings, and coins.



CAUTION:

SHORTING THE BATTERY LEADS CAN DAMAGE THE BATTERY, EQUIPMENT, AND COULD CAUSE INJURY TO PERSONNEL.

Notes

Appendix A: Electrical Specifications

A.1 Operating Power

DC Power The control panel requires connection to AMPS-24, which is a +24 VDC regulated, power-limited power supply, UL/ULC-listed for fire protective service, that can supply 0.1 amps continuous for CPU2-3030ND (0.3 amps for CPU2-3030D). For complete battery/current draw calculations, refer to the main power supply manual; if using an auxiliary power supply, there may be additional calculations in that manual.

A.2 SLC Loops

Listed below are specifications for a Signaling Line Circuit loop. Refer to the *SLC Wiring Manual* for more detailed specifications and specific device listings:

Item	Value
Voltage	24 VDC nominal, 27.6 VDC maximum
Maximum length	The maximum wiring distance of an SLC using 12 AWG (3.25 mm ²) twisted-pair wire is 12,500 ft. (3810 m). Note: Refer to Appendix A.4 "Wire Requirements" for limitations.
Maximum current	130 mA: LCM-320 100 mA: LEM-320 400 mA max*: Single SLC loop *Max short circuit...circuit will shut down until short circuit condition is corrected.
Maximum resistance	50 ohms (supervised and power-limited). For additional notes on SLC resistance values, see Section 5.3 "Operational Checks".

A.3 Notification Appliance Circuits

The FCPS-24S6 and FCPS-24S8 power supplies provide Notification Appliance Circuits. Refer to the FCPS-24S6/S8 manual for product-specific specifications. Refer to the *Device Compatibility Document* for compatible devices and notification appliances. Refer to the *FCPS-24S6/FCPS-24S8 Manual* for complete details about this power supply.

A.4 Wire Requirements

Each type of circuit within the Fire Alarm Control System requires use of a specific wire type to ensure proper circuit operation. The wire gauge of a particular circuit depends on the length of that circuit and the current traveling through it. Use the table below to determine the specific wiring requirements for each circuit.

Compliance with the Federal Communications Commission (FCC) and Canadian Department of Communication regulations on electrical energy radiation requires the following: Use twisted-pair shielded wire for any non-SLC-loop wiring entering or exiting the cabinet that is not enclosed in conduit. Use twisted-pair unshielded wiring for SLC-loop wiring.



NOTE: If running an SLC in conduit with Notification Appliance Circuits, you can reduce problems by exclusively using electronic sounders (such as the MA/SS-24 Series) instead of more electronically noisy notification appliances (such as electromechanical bells or horns).

Circuit Type	Circuit Function	Wire Requirements	Distance (feet/meters)	Typical Wire Type
SLC (power limited)	Connects to intelligent and addressable modules. or or	Twisted-unshielded pair, 12 to 18 AWG (3.25 to 0.75mm ²). 50 ohms, maximum per length of Style 6 & 7 loops. 50 ohms per branch maximum for Style 4 loop.	12,500 ft (3,810 m) 9,500 ft. (2,895.6 m) 6,000 ft. (1,828.8 m) 3,700 ft. (1,127.76 m)	12 AWG (3.31 mm ²) 14 AWG (2.08 mm ²) 16 AWG (1.31 mm ²) 18 AWG (0.82 mm ²)
		Twisted-shielded pair. NOTE: • Shields must be isolated from ground. • Shields should be broken at each device.	5,000 ft (1524 m) 3,700 ft. (1,127.76 m)	12 to 16 AWG (3.31 mm ² to 1.31 mm ²) 18 AWG (0.82 mm ²)
		Untwisted, unshielded wire, in conduit or outside of conduit. NOTE: Maximum total capacitance for all SLC wiring (both between conductors and from any conductor to ground) should not exceed 0.5 microfarads	5,000 ft (1524 m) 3,700 ft. (1,127.76 m)	12 to 16 AWG (3.31 mm ² to 1.31 mm ²) 18 AWG (0.82 mm ²)
EIA-485 ACS Connection (power limited)	Connects to ACS devices such as annunciators and UDACT/UDACT-2	Twisted-shielded pair with a characteristic impedance of 120 ohms. 18 AWG (0.75mm ²) minimum.	6,000 ft (1829 m) (max)	16 AWG (1.31mm ²)
EIA-485 RDP Connection (power limited)	Connects to RDP devices such as LCD-160	Twisted-shielded pair with a characteristic impedance of 120 ohms. 18 AWG (0.75mm ²) minimum.	4,000 ft (1219 m) (max)	16 AWG (1.31 mm ²)
EIA-232 (power limited)	Connects to Printers or PC.	Twisted-shielded pair. 18 AWG (0.75mm ²) minimum.	50 ft (15.24 m) without modem	16 AWG (1.31 mm ²)
IDC Initiating Device Circuit	FMM-1, FMM-101 (power limited)	12-18 AWG Maximum circuit resistance is 20 ohms.		12 to 18 AWG (3.31 to 0.82 mm ²)
NAC Notification Appliance Circuit	FCM-1 (power limited)	12-18 AWG. MPS-24A: At alarm current level, no more than a 1.2 V drop at the end of the circuit, or sized to provide the minimum rated operating voltage of the appliances used.	To meet 1.2 V drop, or sized to provide the minimum rated operating voltage of the appliances used.	12 to 18 AWG (3.31 to 0.82 mm ²)
Releasing Module	FCM-1-REL	12-18 AWG. 5 ohms maximum per circuit for class A or B, or sized to provide the minimum rated operating voltage of the appliances used.	To meet 5 ohms maximum circuit resistance, or sized to provide the minimum rated operating voltage of the appliances used.	12 to 18 AWG (3.31 to 0.82 mm ²)
24 VDC Power Runs (power-limited)	To TM-4 Transmitter, Annunciator and FCM-1 modules	12-18 AWG. Size wire so that no more than 1.2 V drop across wire run from supply source to end of any branch.	To meet 1.2 volt drop	12 to 18 AWG (3.31 to 0.82 mm ²)
CHG-120	External battery charger	12 AWG in conduit	20 ft (6.1 m) maximum	12 AWG (3.31 mm ²)

Table A.1 Wire Requirements

Relay Output circuits are “Common” 30VDC, 2A (see Section 3.9 “Form-C Relays on the CPU”).

Power output circuits: TB6 on the CPU draws power from primary, secondary and external sources to pass +24 VDC power to devices within the same enclosure as the CPU. If those devices have outputs, the outputs must be power-limited. Power rating is determined by the power source(s). See Section 3.10.1 “Overview”, and the *AMPS-24 Manual* for more details.

Appendix B: Canadian Applications

B.1 Standalone Application

CPU2-3030D, with its integral keypad/display, meets Canadian requirements for standalone applications. Its 640-character, multi-line display complies with ULC requirements for primary displays.

B.2 Local Network Application

To meet ULC requirements, the network's Manual Controls may only be operated from one location at any given time.

When panels are networked (using Network Communications Modules or High-Speed Network Communications Modules), employ AKS-1 Key Switch on each panel's Primary Annunciator to enable its functions. NCA-2 may be a Primary Annunciator when AKS-1 is installed. Refer to the *NCA-2 Manual* (P/N 52482) for more information.



NOTE: Only one key should be issued for a networked system.

The NCA-2 or Network Control Station (NCS) may be employed as a Display and Control Center. In the event that communication fails between the panels and the Control Center, the panels will continue to function in local/standalone mode.

B.3 Automatic Alarm Signal Silence

If selecting this feature for a system requiring annunciators, consult the Authority Having Jurisdiction.

B.4 Annunciator Applications

1. In Canada, the ACM series annunciator modules must be used to annunciate the fire alarm input points/zones only, if no multi-line sequential display is installed.
2. For Canadian applications, the following LED colors must be employed:
 - Red must be used to indicate active alarm inputs.
 - Yellow must be used to indicate supervisory, burglary or trouble signals.
 - Green must be used to indicate the presence of power or an activated output.

B.5 Releasing Devices

Supervision for shorts is required; use REL-47K and type code Rel Ckt ULC. Refer to Section 4.6 "Releasing Applications".

B.6 Canadian SLC Devices

For a complete list of ULC-listed SLC loop devices, see *SLC Wiring Manual*, Appendix C "Canadian Versions of SLC Devices".

Index

A

AC Power, *also see* Power **35**
Acceptance Test **58**
ACM-8R **37**
ADP-4B **17**
Agent Release-Abort Station **56**
Alarm Relays *see* Relays **34**

B

Backboxes **14, 17**
 Mounting **21**
Battery
 Battery Calculations **62**
 Battery Checks **59**
 Memory-Backup Battery **26**
Blank Modules **14, 17**
BMP-1 **17, 23**
BP2-4 **17**

C

CAB-4 Series, *also see* Backboxes **17**
Cabinets, *also see* Backboxes **14, 17, 23**
Canadian Applications **64**
Central Receiving Unit, *also see* UDACT Manual **49**
Chassis
 CHS-4L **17**
 CHS-M3 **17, 23, 32**
Circuit Board, *also see* CPU **15**
Control Panel Circuit Board, *also see* CPU **15**
CPU **14, 15**
 Drawing **15**
 Installation Steps **24**

D

DC Power, *also see* Power **35**
Display and Control Center (DCC), *see* Programming Manual
Doors **14, 17**
DP-1B **17**
DP-DISP **17**
Dress Panels **14, 17**

E

Electrical Connections **34**
Electrical Specifications **62**
Enclosures, *see* Backboxes **17**
External Power Supervision **44**

F

FCM-1 **54**
FCM-1-REL **55**
FCPS-24S6/S8 **62**
Fire/Security Applications **47**
FMM-1 **49**
Form-C Relays, *also see* Relays **34**

H

HS-NCM-W/F
 Mounting **29**

I

Indicating Device Circuits, *also see* NACs **62**
Installation
 Checklist **20**
 Preparation **20**

K

Keltron Printer, *also see* Printers **41**

L

LCM-320/LEM-320, *see* SLC Loop Modules
LDM-R32 **37**

M

Main Power Supply **16**
Maintenance **58, 59**
Manual Pull Station **42**
Memory-Backup Battery
 Insulator **26**
Mounting
 Backboxes and Doors **21**

N

NACs
 Specifications **62**
NBG-12LRA **56**
NCM-W/F
 Mounting **29**
Networking **29**
NFPA Applications
 NFPA 72 Central Station Fire Alarm System **45**
 NFPA 72 Remote Station Fire Alarm System **45**
 Overview **44**
 Protected Premises Unit **45**
Non-Power-Limited Circuits

- UL Wiring Requirements **36**
 - Notification Appliance Circuits, *also see* NACs **62**
- O**
- Operating Power **62**
 - Operational Checks **58**
 - Output Relays, *also see* Form-C Relays Specifications **34**
- P**
- PC Connection **43**
 - Periodic Testing **58**
 - Power **35**
 - AC Power Checklist **35**
 - AC Power Connections **35**
 - Auxiliary Power **36**
 - DC Power Connections **35**
 - Installation Steps **34**
 - Main Power Supply **16**
 - Power Supply Calculations **62**
 - Power-Limited Wiring Requirements **36**
 - Specifications **34**
 - PPU **45**
 - Printers **40, 41**
 - Installation **39**
 - PRN Printer Settings **41**
 - Proprietary Fire Alarm Systems **46**
 - Proprietary Security Alarm, *also see* Security **49**
 - Protected Premises Receiving Unit **46**
- R**
- Receiving Unit **46**
 - Related Documentation **8**
 - Releasing **53**
 - FCM-1 connections **54**
 - FCM-1-REL connections **55**
 - NBG-12LRA **56**
 - Remote Connection Feature **39**
- S**
- Security
 - Proprietary Security Alarm Applications Wiring **49**
 - Security Relays, *also see* Relays **34**
 - Security Tamper Switch **48**
 - Service **58**
 - Signalling Line Circuit, *also see* SLC **42**
 - SLC Loop Modules
 - External Power Supervision **44**
 - SLC Loop Number **30**
 - SLC, *also see* SLC Wiring Manual Specifications **62**
 - SLC, *see* SLC Wiring Manual
- Specifications **62**
 - STS-1, *also see* Security **49**
 - Supervisory and Security Contacts
 - Configuring as Alarm Contacts **34**
 - Supervisory Relays, *also see* Relays **34**
 - Supplemental Documentation **8**
 - System
 - Features **12**
 - Limitations **14**
 - Options **12**
 - System Description **12**
 - System Current Draws, *also see* Your Power Supply Manual **62**
- T**
- Testing **58**
 - TM-4 **39**
 - Trouble Relays, *also see* Relays **34**
- U**
- UDACT **39, 45**
 - UDACT-2 **39, 45**
 - UL Non-Power-Limited Wiring Requirements **36**
 - UL Requirements **36**
 - ULC Remote Connection Feature **39**
 - Upload/Download Software **43**
- V**
- VeriFire® Tools **43**
- W**
- Wiring, *also see* SLC **42**
 - Non-Power-Limited Wiring Requirements **36**
 - Proprietary Security Alarm Applications **49**
 - UL Non-Power-Limited Wiring Requirements **36**
 - Wire Requirements **62**

Manufacturer Warranties and Limitation of Liability

Manufacturer Warranties. Subject to the limitations set forth herein, Manufacturer warrants that the Products manufactured by it in its Northford, Connecticut facility and sold by it to its authorized Distributors shall be free, under normal use and service, from defects in material and workmanship for a period of thirty six months (36) months from the date of manufacture (effective Jan. 1, 2009). The Products manufactured and sold by Manufacturer are date stamped at the time of production. Manufacturer does not warrant Products that are not manufactured by it in its Northford, Connecticut facility but assigns to its Distributor, to the extent possible, any warranty offered by the manufacturer of such product. This warranty shall be void if a Product is altered, serviced or repaired by anyone other than Manufacturer or its authorized Distributors. This warranty shall also be void if there is a failure to maintain the Products and the systems in which they operate in proper working conditions.

MANUFACTURER MAKES NO FURTHER WARRANTIES, AND DISCLAIMS ANY AND ALL OTHER WARRANTIES, EITHER EXPRESSED OR IMPLIED, WITH RESPECT TO THE PRODUCTS, TRADEMARKS, PROGRAMS AND SERVICES RENDERED BY MANUFACTURER INCLUDING WITHOUT LIMITATION, INFRINGEMENT, TITLE, MERCHANTABILITY, OR FITNESS FOR ANY PARTICULAR PURPOSE. MANUFACTURER SHALL NOT BE LIABLE FOR ANY PERSONAL INJURY OR DEATH WHICH MAY ARISE IN THE COURSE OF, OR AS A RESULT OF, PERSONAL, COMMERCIAL OR INDUSTRIAL USES OF ITS PRODUCTS.

This document constitutes the only warranty made by Manufacturer with respect to its products and replaces all previous warranties and is the only warranty made by Manufacturer. No increase or alteration, written or verbal, of the obligation of this warranty is authorized. Manufacturer does not represent that its products will prevent any loss by fire or otherwise.

Warranty Claims. Manufacturer shall replace or repair, at Manufacturer's discretion, each part returned by its authorized Distributor and acknowledged by Manufacturer to be defective, provided that such part shall have been returned to Manufacturer with all charges prepaid and the authorized Distributor has completed Manufacturer's Return Material Authorization form. The replacement part shall come from Manufacturer's stock and may be new or refurbished. THE FOREGOING IS DISTRIBUTOR'S SOLE AND EXCLUSIVE REMEDY IN THE EVENT OF A WARRANTY CLAIM.

Warn-HL-08-2009.fm



World Headquarters
12 Clintonville Road
Northford, CT 06472-1610 USA
203-484-7161
fax 203-484-7118

www.notifier.com

ISO 9001
CERTIFIED
ENGINEERING & MANUFACTURING
QUALITY SYSTEMS